

VisioWiFi 10

Interphone vidéo connecté filaire

Connected video intercom wired
Videocitofono collegato cablato
Vídeo portero conectado con cable

PVFO058

VisioWiFi 10



2 fils
100m max



Ecran tactile



Contrôle
à distance



REC
Photos
vidéos



5 mélodies



Gâche
et portail



Notice d'installation et d'utilisation



Installation and user manual



Manuale d'installazione e uso



Instrucciones de instalación y uso

V.092025 IndB

SOMMAIRE

A- Précautions d'utilisation	2
B- Descriptif	2
C- Câblage / Installation	3
D- Utilisation	5
E- Configuration de l'application.....	7
F- Paramétrage.....	9
G- Caractéristiques techniques.....	12
H- Assistance technique.....	13
I- Garantie	14
J- Avertissements	14
K- Déclaration de conformité.....	14

A- PRÉCAUTIONS D'UTILISATION

Ce manuel fait partie intégrante de votre produit. Ces instructions sont pour votre sécurité. Lisez-les attentivement avant utilisation et conservez-les pour une consultation ultérieure. Choisir un emplacement approprié. S'assurer qu'aucun élément ne gêne à l'insertion des chevilles et des vis dans le mur. Ne pas brancher votre alimentation tant que votre installation n'est pas terminée et contrôlée. La mise en œuvre, les connexions électriques et les réglages doivent être effectués dans les règles de l'art par une personne qualifiée et spécialisée. Le bloc d'alimentation doit être installé dans un lieu sec. Vérifier que ce produit est utilisé uniquement pour l'usage auquel il est destiné.

La fonction de ce visiophone est d'identifier un visiteur, il ne doit pas être utilisé pour la surveillance de la rue. L'utilisation de cette installation doit se faire dans le respect de la Loi n° 78-17 du 6 janvier 1978 relative à l'informatique, aux fichiers et aux libertés. Il appartient à l'acheteur de se renseigner auprès de la CNIL en cas de questionnement sur les conditions et les autorisations administratives nécessaires en cas d'usage en dehors d'un cadre strictement personnel. SCS Sentinel ne pourra être tenu responsable en cas d'utilisation de ce produit en dehors des lois et réglementations en vigueur.

Ce produit fonctionne avec l'application iSCS Sentinel uniquement. L'application est disponible gratuitement sur le PlayStore et l'AppStore. Les mises à jour de l'application peuvent être nécessaires, par exemple pour corriger des bugs, améliorer des fonctionnalités, et bénéficier d'une meilleure expérience utilisateur. Vous pouvez activer ou désactiver le caractère automatique des mises à jour de l'application iSCS Sentinel dans les paramètres du PlayStore ou de l'AppStore. Les informations concernant la raison de la mise à jour, son impact sur les performances et l'évolution des fonctionnalités du produit ou de l'application ainsi que l'espace de stockage utilisé, sont indiquées, pour chaque mise à jour, sur le PlayStore ou l'AppStore.

Conformément à la réglementation et la garantie légale, la disponibilité de l'application et de ses mises à jour est garantie pour une durée de 2 ans.

Cette notice peut être amenée à évoluer selon les mises à jour de l'application. Afin d'être sûr d'avoir la dernière version, nous vous conseillons de la télécharger sur notre site internet www.scs-sentinel.com

B- DESCRIPTIF

B1- Contenu du kit / Dimensions

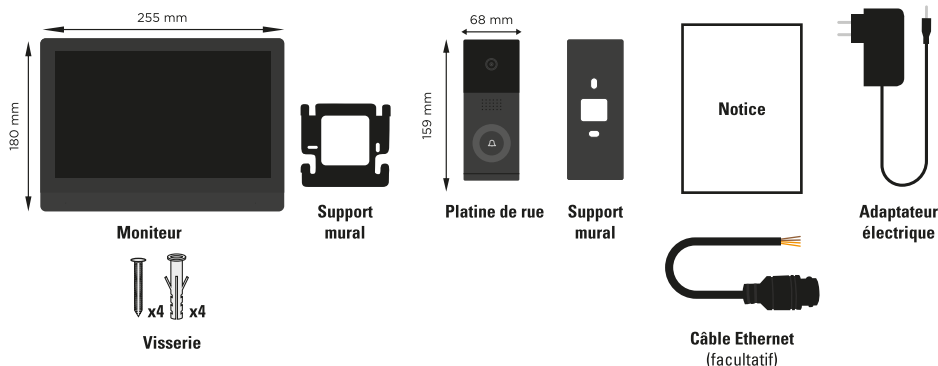

B2- Présentation du produit

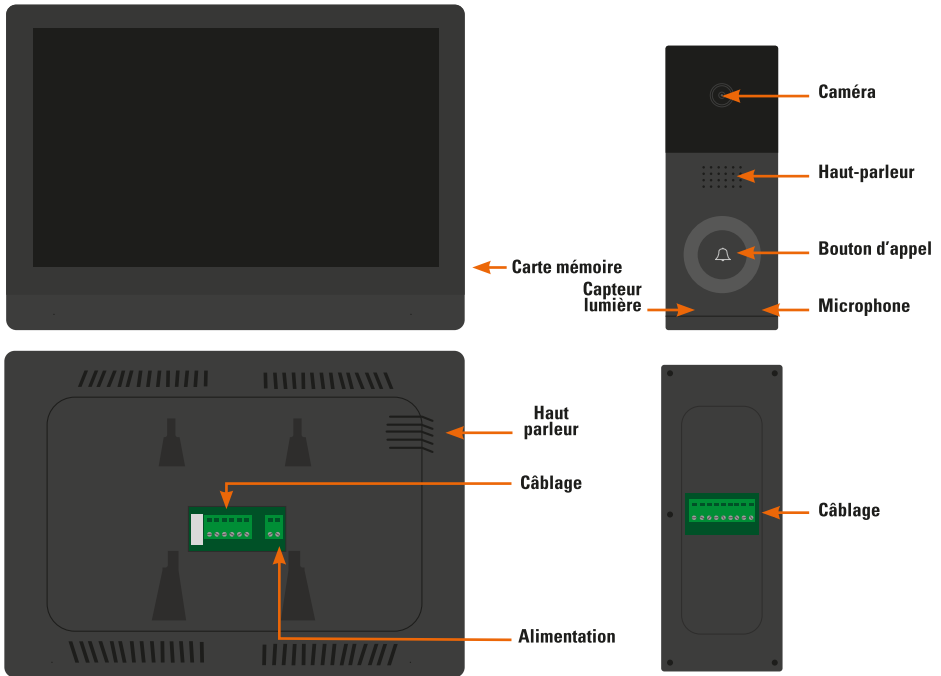

C- CÂBLAGE / INSTALLATION

C1- Installation

Moniteur

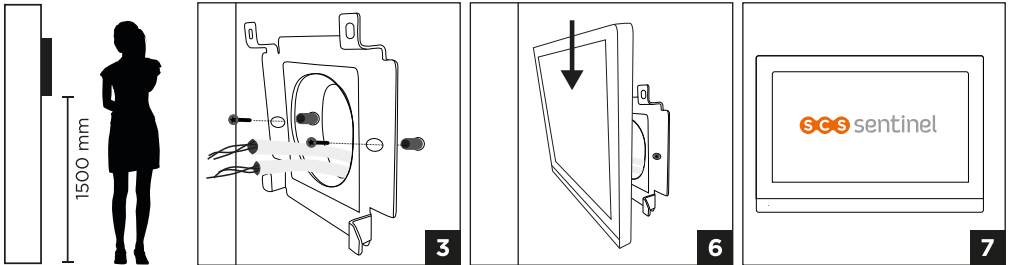

1. Choisir un emplacement approprié pour l'installation du moniteur.
2. Percer 2 trous avec un espacement correspondant à ceux du support mural puis insérer les 2 chevilles fournies. (Les pattes de fixation doivent ressortir vers vous.)
3. Faire passer le câble à travers le trou du support puis le fixer à l'aide de 2 vis fournies.
4. Dénudez les câbles sortant du mur sur une longueur de 10 mm.
5. Brancher les fils conformément au schéma de câblage.
6. Fixer le moniteur sur le support mural en le faisant glisser vers le bas, jusqu'à la butée.
7. Brancher le moniteur pour vérifier que le système fonctionne correctement.

Platine de rue

L'installation sous un porche ou un lieu couvert est recommandée.
Eviter que la lentille de la caméra ne soit en contact direct avec les rayons du soleil.

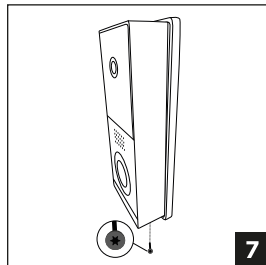
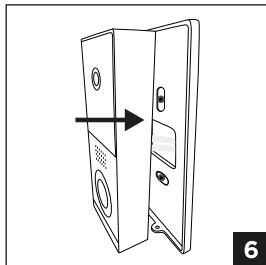
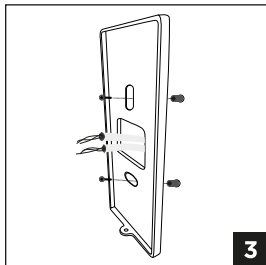
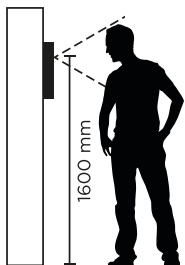

1. Choisir un emplacement approprié pour l'installation de la platine de rue.
2. Percer 2 trous avec un espacement correspondant à ceux du support mural puis insérer les 2 chevilles fournies.
3. Faire passer le câble à travers le trou du support puis le fixer à l'aide de 2 vis fournies.
4. Dénudez les câbles sortant du mur sur une longueur de 10 mm.
5. Brancher les fils conformément au schéma de câblage.
6. Fixer la platine de rue sur le support mural.
7. Vissez la vis de sécurité en bas de la platine de rue.

C2- Schéma de câblage

Sans polarité

0 - 100 m - 0,75 mm²

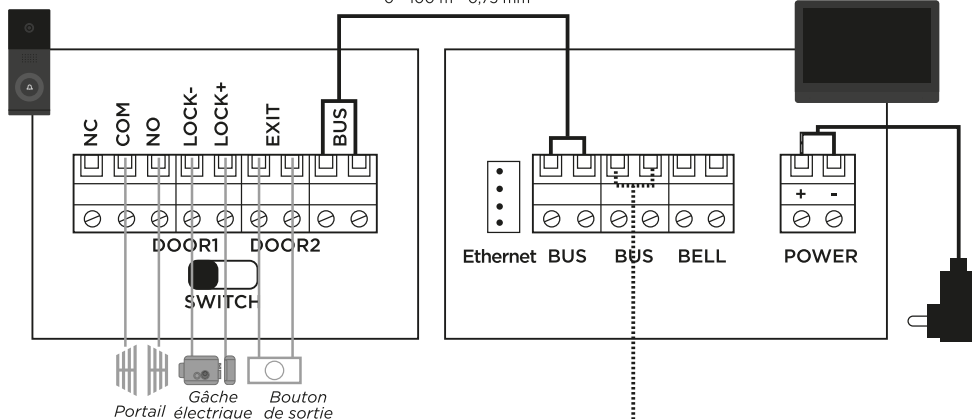

Éléments additionnels

Il est possible de connecter jusqu'à 6 moniteurs et 2 platines de rue.

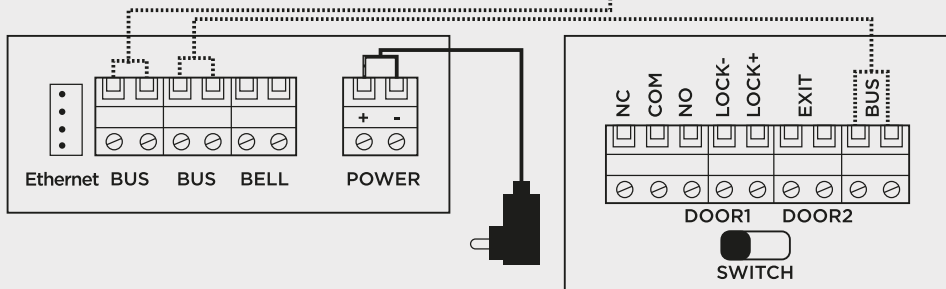

⚠ Si deux platines de rue sont installées, il faut impérativement positionner le switch sur «door1» et l'autre switch sur «door2», sinon il y aura conflit d'adresses.

D- UTILISATION

D1- Appel depuis la platine de rue



Changement de platine de rue



Enregistrer une photo



Enregistrer une vidéo (Carte SD)



Ouverture gâche / serrure



Ouverture portail



Réglages écran / volume / luminosité...



Décrocher (120 sec. max)



Raccrocher
Retour à l'accueil

D2- Écrans principaux

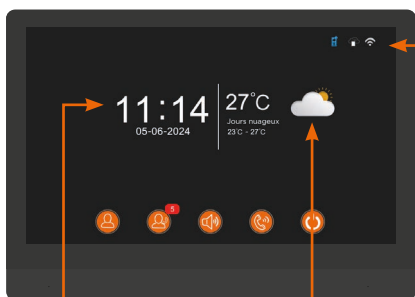

Heure & date

Météo
Le moniteur affiche automatiquement la météo s'il est connecté à Internet



Platine connectée



Téléphone appairé



Wi-Fi connecté



Wi-Fi déconnecté



Platines
Vue de la caméra



Appel
Fonction inter-communication entre les moniteurs



Journal d'appel



Veille
Pour quitter le mode veille, toucher l'écran



Silencieux
Coupe la sonnerie du moniteur

Toucher l'écran pour accéder aux réglages :

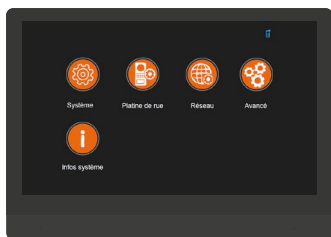

Système

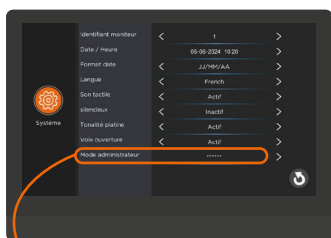

Mode administrateur

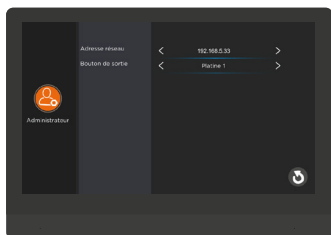

Choisir l'action du bouton de sortie :
 Ouverture de la gâche
 Ouverture du portail
 Ouverture des deux en même temps

Platine de rue

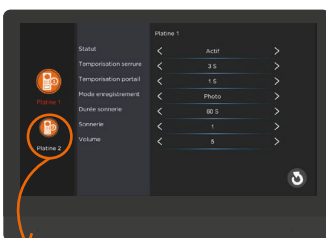

Statut
 Si installation d'une deuxième platine de rue, modifier le statut d'inactif > actif

Réseau

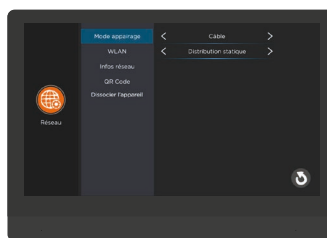

Mode appairage
 Câble : Connexion en ethernet
 Mode EZ : Connexion en Wi-Fi

WLAN
 Configuration Wi-Fi

Avancé

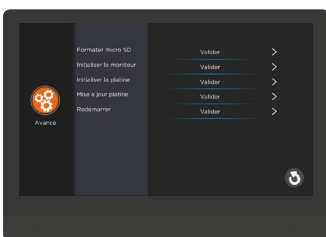

Infos système

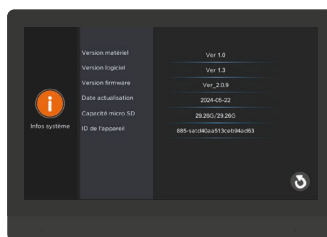

Initialiser le moniteur / la platine :
 Cette fonction permet de rétablir toutes les données et tous les réglages initiaux de l'appareil.

E- CONFIGURATION DE L'APPLICATION

Installation de l'application



iSCS Sentinel

Pour télécharger l'application, connectez-vous sur l'App Store ou le Play Store de votre smartphone. Recherche «iSCS Sentinel», cliquez ensuite sur Installer.



Lorsque le téléchargement est terminé, ouvrir l'application et cliquer sur «CRÉER MON COMPTE.»



Renseigner l'adresse mail ainsi que le mot de passe dans les cases correspondantes.

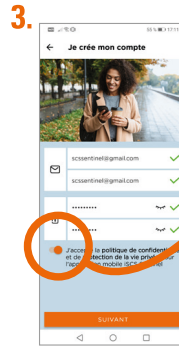

Appuyer sur «SUIVANT».



Il est nécessaire d'accepter la politique de confidentialité avant de cliquer sur suivant.

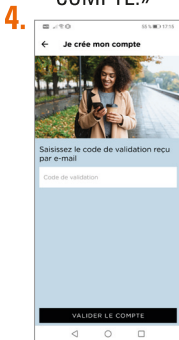

Renseigner le code de validation reçu par mail. Puis valider le compte.

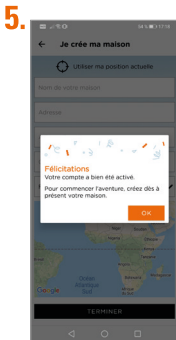

Appuyer sur «AUTORISER».

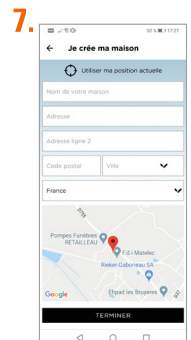

Renseigner toutes les informations demandées pour créer une maison. Cliquer sur «TERMINER».

Ajout du moniteur



Brancher l'alimentation du moniteur et le placer à proximité du routeur Wi-Fi. Le téléphone doit être connecté au même réseau Wi-Fi que le moniteur et la localisation doit être activée.



Certains matériaux peuvent réduire la portée du signal Wi-Fi.

100%	Champ libre
80%	Bois, verre
60-70%	Cloison placoplâtre
50-70%	Pierre
20-50%	Béton
<10%	Métal

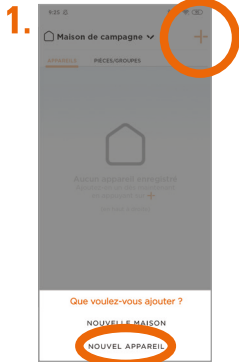

Appuyer sur **+** puis sur «**NOUVEL APPAREIL**» pour ajouter le visiophone.



Le réseau doit être en 2.4 GHz pour fonctionner.

2.4 GHz

Renseigner la clé Wi-Fi, flasher le QR Code au dos du moniteur ou entrer le code manuellement.



Branchez le moniteur et allez dans réseau > WLAN (entrez les informations de connexion.) Cliquez sur QR Code (scannez le QR Code qui s'affiche sur le moniteur)

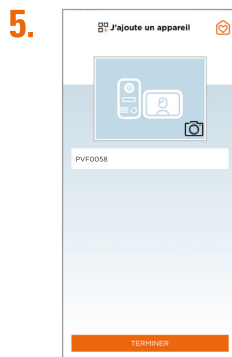

Nommer le visiophone et la pièce dans laquelle le produit se trouve.

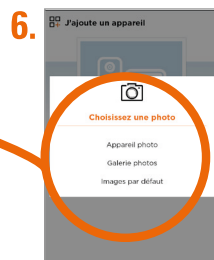

Ajouter une photo de profil à partir de l'appareil photo, de la galerie photo, ou sélectionner une image par défaut (visuel du produit ou dernière capture de mouvement.)

F- PARAMÉTRAGE

Réglages de l'application



Appuyer sur  pour accéder aux réglages de l'application.

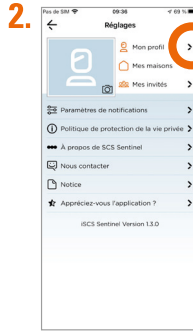

Voir mon profil :
pour modifier les informations personnelles

Pour ajouter une maison



Cliquer sur +

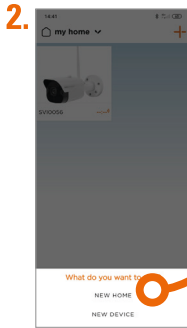

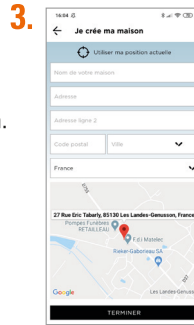

Créer une nouvelle maison.

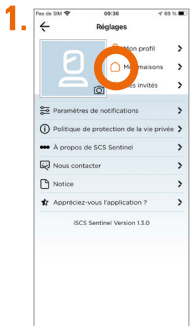

Renseigner les champs et appuyer sur «TERMINER».

Pour supprimer une maison



Appuyer sur 



Appuyer sur  pour supprimer une maison.

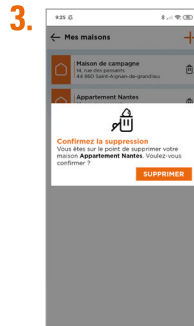

Pour modifier une maison

- 



Appuyer sur 
- 

Modifier l'adresse.
- 

ENREGISTRER

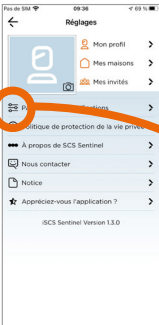
Paramètres de notifications

- 

Appuyer sur  pour accéder aux paramètres de notifications.
- 

Appuyer sur «Activer les notifications» pour activer la totalité des notifications. Sinon appuyer sur les notifications souhaitées.

Utilisation de l'application

- 

Appuyer pour parler.
- 

Capturer la photo dans votre téléphone.
- 

Capturer la vidéo dans votre téléphone.
- 

Déclencher le portail
- 

Gestion des platines de rue
- 

Déclencher la gâche

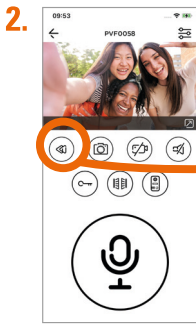

2. Replay : visionner ce qu'il s'est passé.

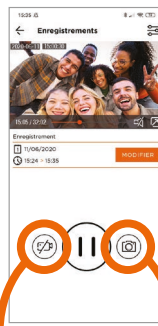

Enregistrer une vidéo

Enregistrer une photo

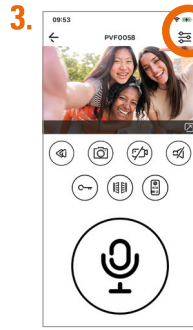

3. Appuyer sur  pour modifier les paramètres du visionneur.



Par défaut, le visiophone apparaîtra dès l'ouverture de l'application dans la liste des favoris.

Appuyer sur  pour ajouter/supprimer le visiophone des favoris.

Scénarios

Un scénario est une action qui suit un/des événement(s) déclencheurs

- 1 Sélectionnez le/les événements déclencheurs. Si vous avez plusieurs déclencheurs, vous avez le choix entre les combiner ensemble (ET) ou les dissocier pour réaliser l'action (OU).
- 2 Définissez le/les actions à réaliser.
- 3 Enregistrez votre scénario.

Ensuite, l'application lancera le/les action(s) du scénario, lorsqu'il aura repéré un déclencheur

SUIVANT



2. Pour sélectionner un ou des événements déclencheurs (appareil, date/heure ou lieu) appuyer sur +



3. Pour sélectionner une ou des actions (appareil, notification ou délai) appuyer sur +

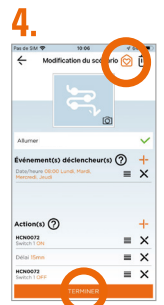

4. Par défaut, le scénario apparaîtra dans la liste des favoris.

 Le scénario est activé 

 Activer les «actions» du scénario sans attendre les «événements déclencheurs»



Ajouter des invités

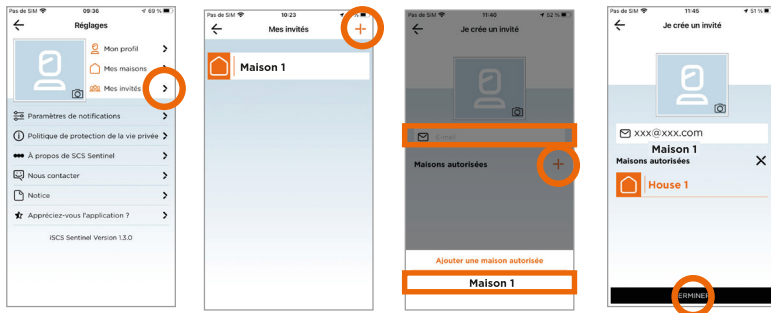

⚠ Via l'application **iSCS Sentinel**, un invité peut activer / désactiver les appareils mais il ne peut pas les paramétrer.

Reset

Pour totalement supprimer l'appareil il faudra le supprimer dans l'application.

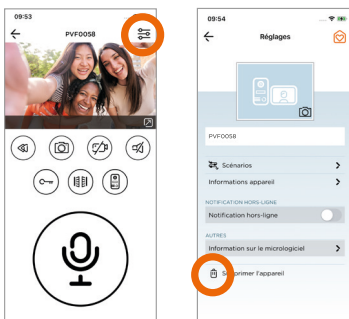

G- CARACTÉRISTIQUES TECHNIQUES

Moniteur

Alimentation	24V DC 1A 24W
Ecran	Ecran tactile 10" TFT LCD
Dimensions	255 x 180 x 28,5 mm
Résolution LCD	1024 x 600 px
Mémoire externe possible sur carte micro SD (photos ou vidéos)	4 Go - 128 Go classe 4 (non fournie) la carte micro SD doit être formatée avant utilisation
Fréquence de fonctionnement	2412 MHz - 2472 MHz
Puissance maximale d'émission	< 100mW
Wi-Fi	802 11b/g/n

Platine de rue

Alimentation	23V DC 0,2A
Dimensions	68 x 159 x 31 mm
Résolution HD	1080 x 720 px
Angle de vue	110°
Vision nocturne	LED infrarouges
Température de fonctionnement	-20°C /+ 50°C
Indice de protection	IP65

Adaptateur électrique

Référence du modèle	MX24W1-2401000V
Tension d'entrée	100-240V AC
Fréquence du CA d'entrée	50/60Hz
Courant de sortie	1A
Puissance de sortie	24W
Rendement moyen en mode actif	88,29%
Rendement à faible charge (10%)	84,51%
Consommation électrique hors charge	0,084W
Tension de sortie	24V DC

Mode veille

Consommation d'énergie en mode veille	3.8W
Délai pour la mise en veille	15 minutes

H - ASSISTANCE TECHNIQUE

Conseils d'expert

En cas de besoin, vous pouvez prendre contact avec nos experts au numéro ci-dessous.

Notre équipe de techniciens et de techniciennes, basée en France, assure un conseil avisé et personnalisé.



0 892 350 490 Service 0,15 €/min
+ prix appel

Horaire du service, voir sur le site internet : scs-sentinel.com/contact

Nous vous demandons au préalable de relever la référence de votre matériel sur la notice ou l'emballage de votre produit.

Nous vous conseillons également de brancher votre matériel « en fils volants » sur une table après avoir démonté les éléments.

Prenez rendez-vous avec nos experts



Notre service de prise de rendez-vous par visioconférence est là pour vous aider.

Ces sessions sont spécialement conçues pour répondre à vos besoins en installation ou dépannage de manière efficace et ciblée. Grâce à la visioconférence, vous pouvez montrer à notre équipe d'experts votre installation actuelle, poser des questions en temps réel et bénéficier de conseils précis étape par étape pour résoudre vos problèmes rapidement.

Pour plus d'informations sur ce service payant, rendez-vous sur notre site internet scs-sentinel.com > (services)

Chat' en ligne



Une question ?

Pour une réponse personnalisée, utilisez notre chat' en ligne sur notre site web www.scs-sentinel.com

I- GARANTIE



SCS Sentinel accorde à ce produit une garantie supérieure à la durée légale, en gage de qualité et de fiabilité.

Il est impératif de garder une preuve d'achat durant toute la période de garantie.

Conservez soigneusement le code-barre ainsi que votre justificatif d'achat, il vous sera demandé pour faire jouer la garantie.

J- AVERTISSEMENTS

- Garder une distance minimale (10 cm) autour de l'appareil pour une aération suffisante.
 - Ne pas gêner l'aération par l'obstruction des ouvertures d'aération par des objets tels que journaux, nappes, rideaux, etc.
 - Ne pas approcher l'appareil de flammes nues, telles que des bougies allumées.
 - Le fonctionnement normal du produit peut être perturbé par une forte interférence électromagnétique.
 - Cet équipement est destiné à un usage privé uniquement.
 - Le moniteur et son adaptateur ne doivent pas être exposés à des égouttements d'eau ou des éclaboussures. Aucun objet rempli de liquide tel que des vases ne doit être placé sur ces appareils.
 - La prise du réseau d'alimentation doit demeurer aisément accessible. Elle est utilisée comme dispositif de déconnexion.
 - Le moniteur et l'adaptateur doivent être utilisés en intérieur.
 - Effectuer tous les branchements entre les éléments avant d'alimenter le kit.
 - Ne brancher votre appareil qu'avec l'adaptateur fourni.
 - Les éléments étant composés d'électronique, ils sont à manipuler avec précaution.
 - Ne pas boucher le microphone de la platine de rue et du moniteur.
- Lors de l'installation de votre produit, ne pas laisser les emballages à la portée des enfants ou des animaux. Ils représentent une source potentielle de danger.
- Ce produit n'est pas un jouet. Il n'a pas été conçu pour être utilisé par des enfants.

 Avant tout entretien, débrancher vos appareils. Ne pas nettoyer le produit avec des solvants, des substances abrasives ou corrosives. Utiliser un simple chiffon doux pour nettoyer l'écran du moniteur. Ne rien vaporiser sur le produit.

 Assurez-vous de la bonne maintenance de votre produit et vérifiez fréquemment l'installation pour déceler tout signe d'usure. N'utilisez pas l'appareil si une réparation ou un réglage est nécessaire. Faites appel à du personnel qualifié.

 Ne jetez pas les appareils hors d'usage avec les ordures ménagères. Les substances dangereuses qu'ils sont susceptibles de contenir peuvent nuire à la santé et à l'environnement. Utilisez les moyens de collectes sélectives mis à votre disposition par votre commune ou votre distributeur.



Explication des symboles :

 Courant continu

 Modèle de classe II

 Le moniteur et l'adaptateur sont destinés à une utilisation intérieure uniquement

 Courant alternatif

IP 65 : L'unité extérieure est protégée contre la poussière et contre les jets d'eau de toutes les directions à la lance.

K- DÉCLARATION DE CONFORMITÉ

Par la présente, SCS Sentinel déclare que ce produit est conforme aux exigences essentielles et autres dispositions pertinentes de la directive 2014/53/UE. La déclaration de conformité peut être consultée sur le site : www.scs-sentinel.com/downloads

TABLE OF CONTENTS

A- Safety instructions	15
B- Description	15
C- Wiring / Installation	16
D- Use	18
E- Configuration	20
F-Setting	22
G-Technical features	26
H- Technical assistance	27
I-Warranty.....	27
J- Warnings.....	27
K- Declaration of conformity	27

A- SAFETY INSTRUCTIONS

This manual is an integral part of your product. These instructions are provided for your safety. Read this manual carefully before installing and keep it in a safe place for future reference. Select a suitable location. Make sure you can easily insert screws and wallplugs into the wall. Do not connect your electrical appliance until your equipment is totally installed and controlled. The installation, electric connections and settings must be made using best practices by a specialized and qualified person. The power supply must be installed in a dry place. Check the product is only used for its intended purpose.

The function of this videophone is to identify a visitor, it must not be used for street surveillance. The use of this installation must be in compliance with the French law n° 78-17 of January 6, 1978 relating to data processing, files and freedoms. It is up to the buyer to ask the CNIL about the conditions and administrative authorisations required for use outside a strictly personal context. SCS Sentinel cannot be held responsible in case of use of this product outside the laws and regulations in force.

This product works with the iSCS Sentinel app only. The application is available for free on the PlayStore and the AppStore. Application updates may be necessary, for example to fix bugs, improve features, and benefit from a better user experience. You can enable or disable automatic updates for the iSCS Sentinel application in the PlayStore or AppStore settings. The information concerning the reason for the update, its impact on the performance and the evolution of the functionalities of the product or application as well as the storage space used, are indicated, for each update, on the PlayStore or the AppStore.

In accordance with the regulations and the legal guarantee, the application availability and updates are guaranteed for a period of 2 years. **This manual may be amended as the application is updated. To ensure you have the latest version, we recommend you download it from our website www.scs-sentinel.com**

B- DESCRIPTION

B1- Content / Dimensions

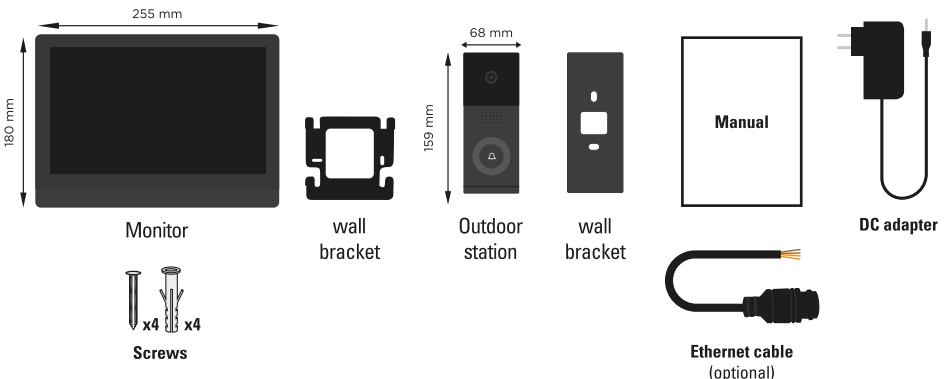

B2- Product presentation

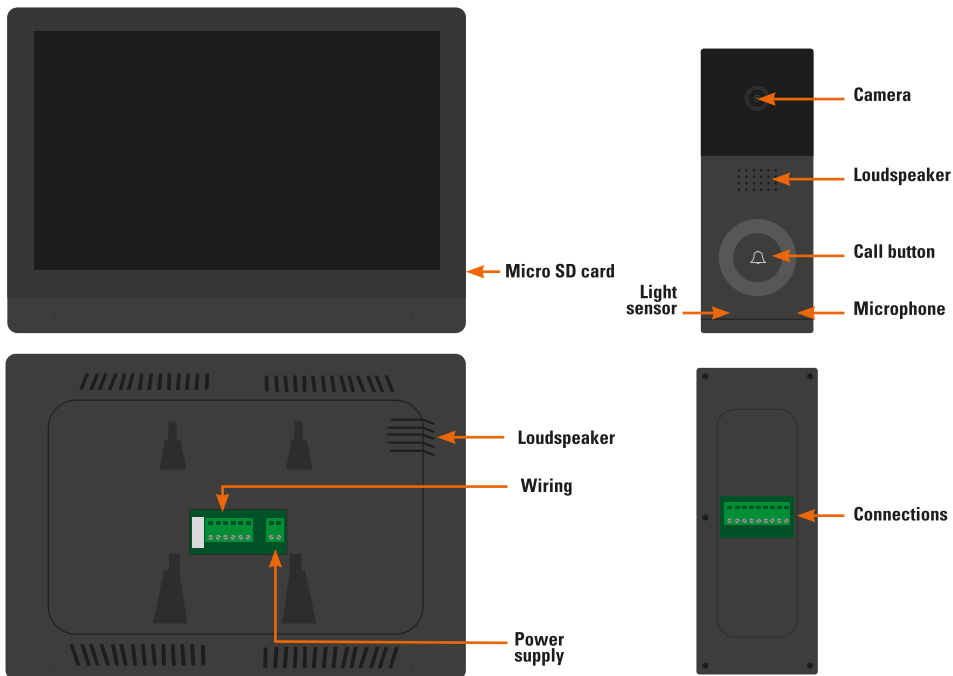

WIRING / INSTALLATION

C1- Installation

Indoor monitor

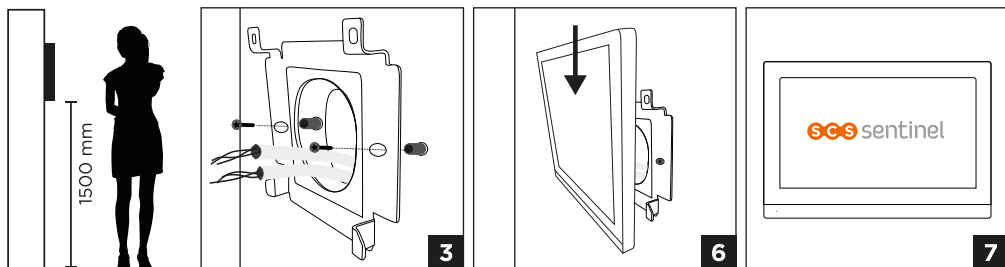

1. Choose a suitable location for the monitor.
2. Drill 2 holes with a spacing corresponding to that of the support, then insert the 2 wall plugs supplied. (The fixing lugs should protrude towards you.)
3. Pass the cable through the hole in the wall bracket and secure it with the 2 screws supplied.
4. Strip the cables coming out of the wall to a length of 10 mm.
5. Connect the wires in accordance with the wiring diagram.
6. Attach the monitor to the wall bracket by sliding it down as far as it will go.
7. Switch on the monitor to check that the system is operating correctly.

Outdoor monitor

Installation in a porch or covered area is recommended.
Avoid the camera lens coming into direct contact with the sun's rays.

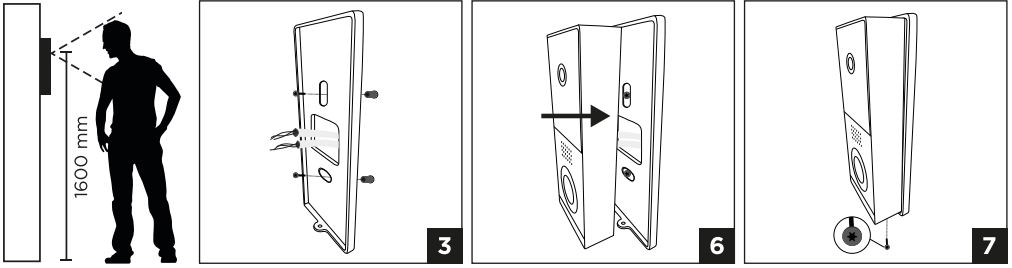

1. Choose a suitable location for the monitor.
2. Drill 2 holes a spacing corresponding to that of the support, then insert the 2 wall plugs supplied.
3. Pass the cable through the hole in the wall bracket, then fix it to the wall using the 2 screws supplied.
4. Strip the cables coming out of the wall to a length of 10 mm.
5. Connect the wires in accordance with the wiring diagram.
6. Fix the door station to the wall bracket.
7. Screw in the security screw at the bottom of the door station.

C2- Wiring diagram

No polarity

0 - 100 m - 0,75 mm²

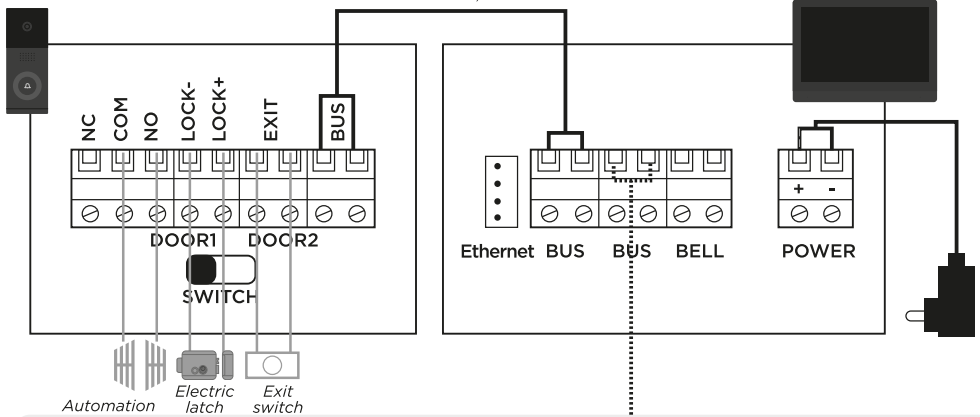

Additional elements

Up to 6 monitors and 2 door stations can be connected.

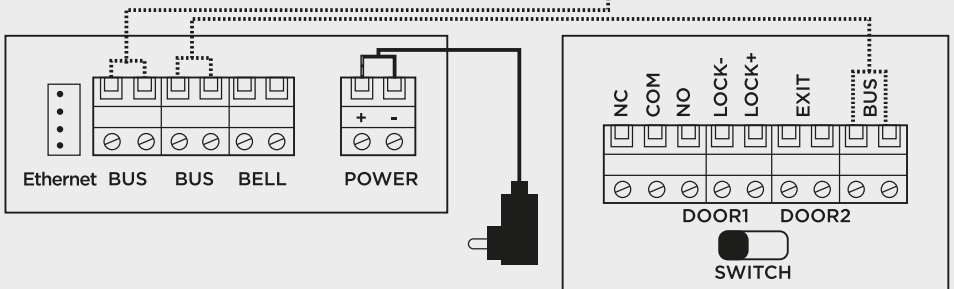









⚠ If two door loudspeakers are installed, it is essential to position the switch on 'door1' and the other switch on 'door2', otherwise there will be an address conflict.

D- USE

D1- Call from the outdoor station





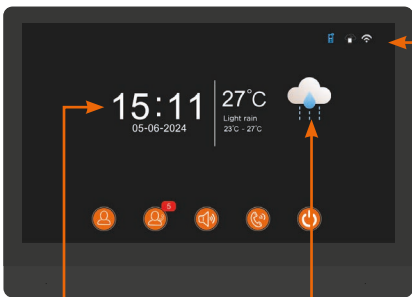

	Change door station		Save a photo		Save a video (Carte SD)
	Open strike plate / lock		Open the gate automation		Settings screen / volume / brightness...
	Pick up (120 sec. max)		Hang up Back to home screen		

D2- Main screens



	Door station connected		Phone paired		Wi-Fi connected
					Wi-Fi disconnected

	Monitor Camera view		Call Function inter-communication between monitors
	Call log		Standby To exit standby mode, touch the screen
	Silent Turns off the monitor		

Time & date

Weather
The monitor automatically displays the weather forecast if it is connected to the Internet

Touch the screen to access the settings:

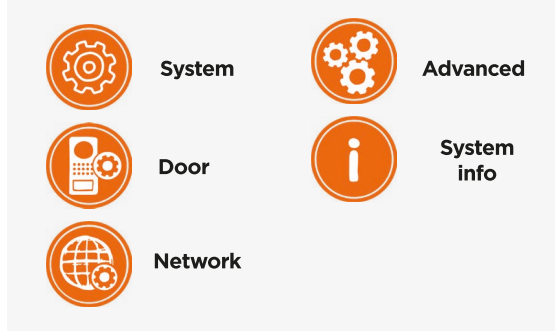
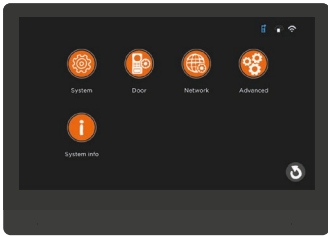

System

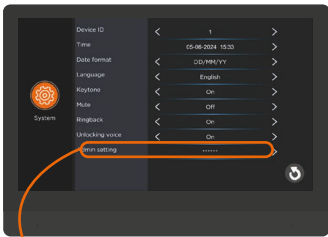

Admin setting

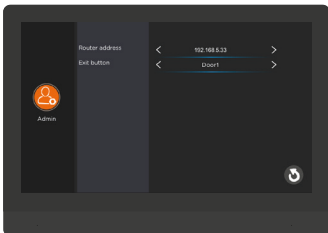

Choose the action of the exit button :
 Open the strike
 Gate opening
 Open both at the same time

Door

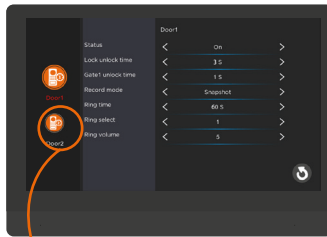

Status
 If a second door station is installed, change the status from inactive > active

Network

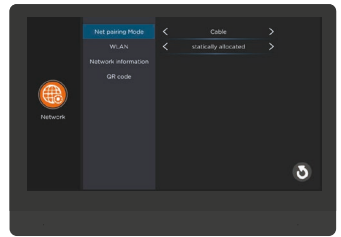

Pairing mode
 Cable: ethernet connection
 EZ mode: Wi-Fi connection

WLAN
 Wi-Fi configuration

Advanced

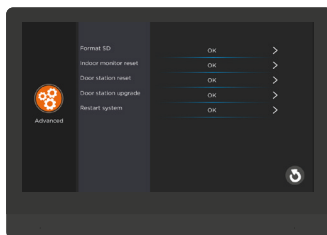

Initialise monitor / deck :
 This function restores all the device's initial data and settings.

System Info

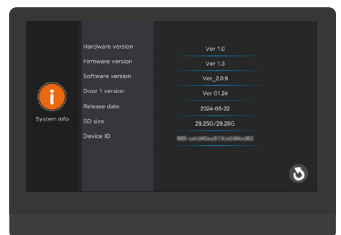

E- APPLICATION CONFIGURATION

Installing the app



iSCS Sentinel

To download the app, go on to the App Store or Play Store on your smartphone. Search for “iSCS Sentinel”, then click on install.



Once the download is complete, open the app and click on create my account.

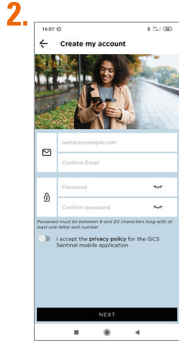

Enter your email address and password in the relevant boxes.

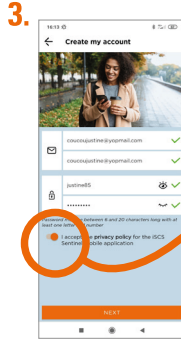

Click «next».



Please agree to the privacy policy before clicking next.

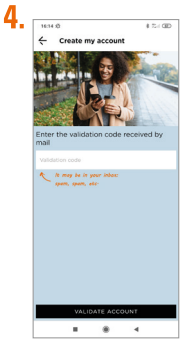

Enter the validation code you received by email. Then confirm the account.

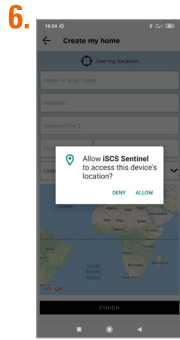
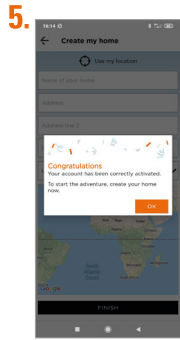

Click on allow.

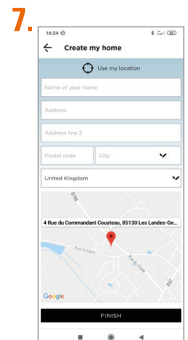

Enter all the information requested to create your home. Then click on finish.

Adding the monitor



Plug in the power to the monitor and place it near your Wi-Fi router. Your phone must be connected to the same Wi-Fi network as your monitor and location must be enabled.



Some materials may reduce the Wi-Fi range.

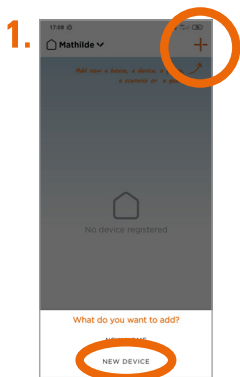
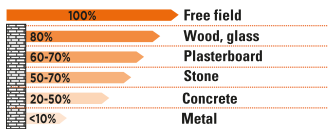

1. Click on **+** than on **"NEW DEVICE"** to add your product.

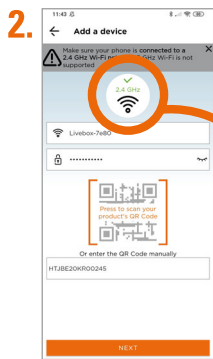

The network needs to be 2.4 GHz to work.



2. Enter your Wi-Fi key, scan the QR code on the back of the monitor or enter the code manually

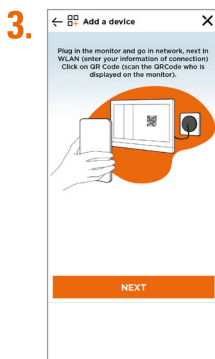

3. Plug in the monitor and go to Network > WLAN (enter your connection details) Click on QR Code (scan the QR Code displayed on the monitor)

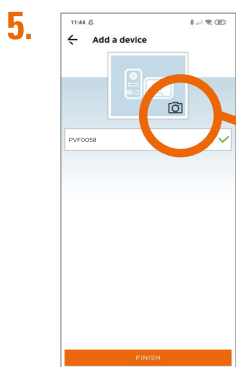
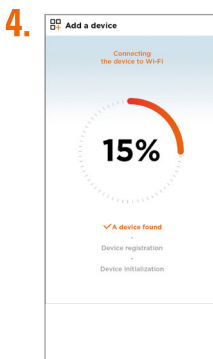

5. Enter a name for the product and the room in which it is located.

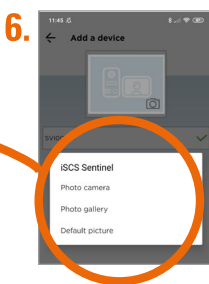

6. Add a profile picture from your camera, the gallery or select a picture by default (product visual or last motion capture).

F- SETTING

Application settings

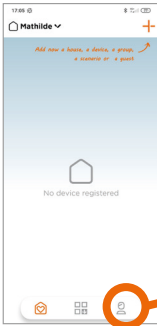
- 

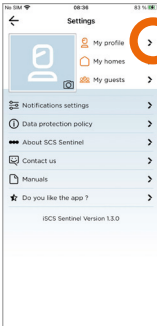
1. Click on  to go to the app settings.
- 

2. View my profile: to change personal information

To add a home

- 

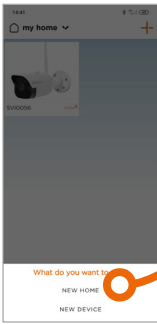

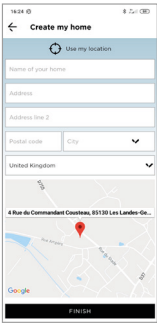
1. Click on 
- 

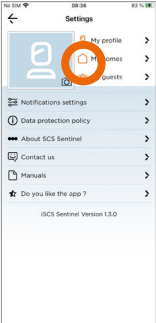

2. Create a new home.
- 

3. Fill in the fields and click on "finish".

To remove a home

- 



1. Click on 
- 

2. Click on  to remove a home.
- 

3.

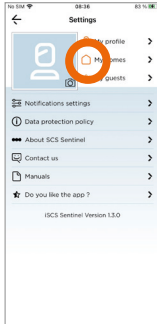
To edit a home

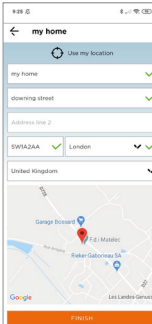

- 

Click on 
- 

Edit the address.
- 

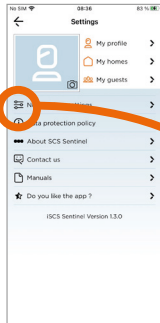
Notification settings

- 

Click on  to go to the notification settings.
- 

Click on « enable notification » to activate all notifications. Otherwise click on the desired notifications.

Using the app

- 

Click to speak.
- 

Take a photo on your phone.
- 

Activate full screen (tilt the phone).
- 

Record the video on your phone.
- 

Open or close the gate
- 

Outdoor station management
- 

Release the electric lock

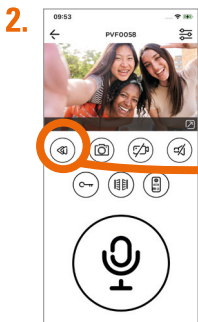

2. **Replay :**
view what happened.

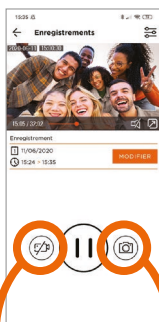

Save a video

Save a photo



3. Click on to change the product settings.



By default, the product will appear when the app is opened in the favourites list.

Click on to add/remove the product from favourites.

Scenarios

A scenario is an action that follows a triggering event(s).

- 1 Select the trigger event(s). If you have several triggers, you could combine them together (AND) or dissociate them to carry out the action (OR).
- 2 Define the action(s) to carry out.
- 3 Register your scenario.

Then, the app will start the scenario action(s) when the trigger would be detected.

NEXT



2. To select one or more trigger events (device, date/time or location) press +.

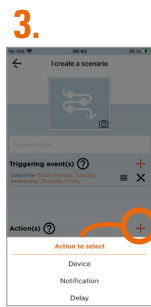

3. To select one or more actions (device, notification or delay) press +.

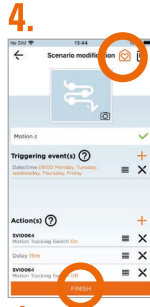

4. By default, the scenario will appear in the favourites list.

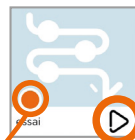

● The scenario is activated

▶ Activate the «actions» of the scenario without waiting for the «triggering events».

To add guests

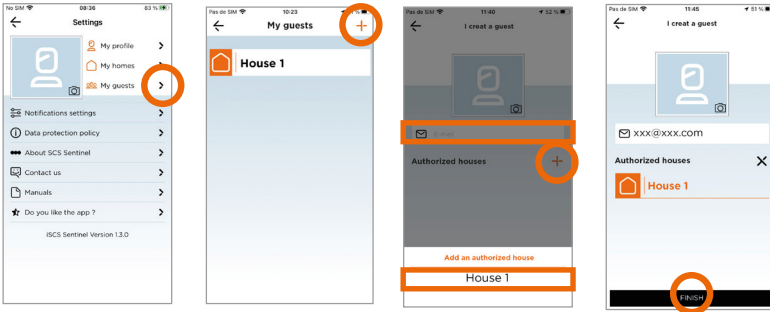

⚠ Via the iSCS Sentinel app, your guest can activate/deactivate the devices but cannot configure them.

Reset

To completely remove the device, you will need to delete it from the app.

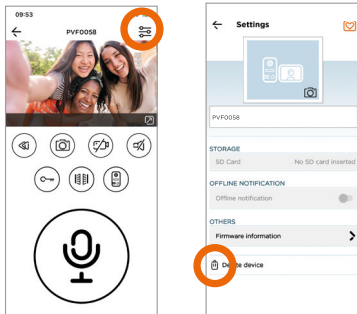

G- TECHNICAL FEATURES

Indoor monitor

Input power	24V DC 1A 24W
Screen	7 inch digital TFT LCD touch screen
Dimensions	181 x 181x 18 mm
LCD resolution	1024 x 600 px
Memory capacity (photos)	90 Mo. when full the newest photo will automatically overwrite the oldest one
External memory capacity (photos or videos)	MicroSD card 4 Go - 128 Go classe 4 (not supplied) MicroSD card must be formatted by monitor before using
Functioning frequency	2412 MHz - 2472 MHz
Maximum transmitted power	< 100mW
Wi-Fi	802 11b/g/n

Outdoor station

Input power	23V DC 0,2A
Dimension	68 x 159 x 31 mm
Resolution	1080 x 720 px
Angle view	110°
Night vision	IR LED
Operation temperature	-20°C /+ 50°C
Protection rating	IP65

Adapter

Model identifier	MX24W1-2401000V
Input voltage	100-240V AC
Input AC frequency	50/60Hz
Output voltage	24V DC
Output current	1A
Average active efficiency	88,29%
Efficiency at low load (10%)	84,51%
No-load power consumption	0,084W

Standby mode

Energy consumption in standby mode	3,8W
Standby timeout	15 minutes

H - TECHNICAL ASSISTANCE

Online assistance



Any question ?

For an individual answer, use our online chat on our website www.scs-sentinel.com

I- WARRANTY



SCS Sentinel grants to this product a warranty period, beyond the legal time, as a sign of quality and reliability.

The invoice will be required as proof of purchase date. Please keep it during the warranty period.

Carefully keep the barcode and the proof of purchase, that will be necessary to claim warranty.

J- WARNINGS

- Maintain a minimum distance of 10 cm around the device for sufficient ventilation.
- Be sure that the device is not blocked by paper, tablecloth, curtain or other items that would impede airflow.
- Keep matches, candles and flames away from the device.
- Product functionality can be influenced by a strong electromagnetic interference.
- This equipment is intended for private consumer use only.
- The monitor and its adapter must not be exposed to dripping or splashing water. No objects filled with liquids, such as vases, should be placed on top of this equipment.
- The mains plug is used as disconnect device and shall remain readily operable during intended use.
- The monitor and the adapter must only be used indoors.
- Connect all the parts before switching on the power.
- Only connect your appliance using the provided adapter.
- Do not cause any impact on the elements as their electronics are fragile.
- Do not block the microphone.
- When installing the product, keep the packaging out of reach of children and animals. It is a source of potential danger.
- This appliance is not a toy. It is not designed to be used by children.

 Disconnect the appliance from the main power supply before service. Do not clean the product with solvent, abrasive or corrosive substances. Only use a soft cloth. Do not spray anything on the appliance.

 Make sure that your appliance is properly maintained and regularly checked in order to detect any sign of wear. Do not use it if a repair or adjustment is needed. Always call on qualified personnel.

 Don't throw out of order products with the household waste (garbage). The dangerous substances that they are likely to include may harm health or the environment. Make your retailer take back these products or use the selective collect of garbage proposed by your city.

 Direct current

 Alternating current

 Model class II

 The monitor and the adaptor is for indoor use only

IP 65 : The outdoor unit is protected against dust and water jets from all directions.



K- DECLARATION OF CONFORMITY

Hereby, SCS Sentinel declares that this product complies with the essential requirements and other relevant provisions of Directive 2014/53/UE. The UE declaration of conformity may be consulted on the website : www.scs-sentinel.com/downloads.

INDICE

A- Precauzioni per l'uso	28
B- Specifiche.....	28
C- Cablaggio / Installazione	29
D- Utilizzo.....	31
E- Configurazione dell'applicazione.....	33
F- Configuration	35
G- Caratteristiche tecniche	39
H- Assistenza tecnica.....	40
I-Garanzia.....	40
J-Avvertenze.....	40
K-Dichiarazione UE di conformità.....	41

A- PRECAUZIONI PER L'USO

Il presente manuale costituisce parte integrante del prodotto. Queste istruzioni vengono fornite per vostra sicurezza. Siete pregati di leggerle con attenzione prima dell'uso e di conservarle per future esigenze di consultazione. Scegliere la posizione idonea. Verificare che non ci siano elementi che disturbano l'inserimento nel muro di viti e tasselli. Non collegare l'alimentazione prima di aver terminato e controllato l'installazione. L'installazione, i collegamenti elettrici e le regolazioni devono essere eseguiti a regola d'arte da un addetto qualificato e specializzato. L'unità di alimentazione deve essere installata in un luogo asciutto. Verificare che questo prodotto venga utilizzato esclusivamente per l'uso a cui è destinato.

La funzione di questo videotelefono è quella di identificare un visitatore, non deve essere utilizzato per la sorveglianza stradale. L'utilizzo di questo impianto deve essere conforme alla legge francese n° 78-17 del 6 gennaio 1978 relativa al trattamento dei dati, dei file e delle libertà. Spetta all'acquirente informarsi presso la CNIL sulle condizioni e le autorizzazioni amministrative necessarie per l'utilizzo al di fuori di un contesto strettamente personale. SCS Sentinel non può essere ritenuta responsabile in caso di utilizzo di questo prodotto al di fuori delle leggi e dei regolamenti in vigore. Questo prodotto funziona solo con l'applicazione iSCS Sentinel. L'applicazione è disponibile gratuitamente su PlayStore e AppStore. Può essere necessario aggiornare l'applicazione, ad esempio per risolvere bug, migliorare la funzionalità e fornire una migliore esperienza all'utente. È possibile attivare o disattivare gli aggiornamenti automatici dell'applicazione iSCS Sentinel nelle impostazioni di PlayStore o AppStore. Informazioni sul motivo dell'aggiornamento, sul suo impatto sulle prestazioni e sull'evoluzione delle funzionalità del prodotto o dell'applicazione, nonché sullo spazio di archiviazione utilizzato, sono indicate su PlayStore o AppStore per ogni aggiornamento.

In accordo con la normativa e la garanzia legale, la disponibilità dell'applicazione e dei suoi aggiornamenti è garantita per un periodo di 2 anni.

Il presente manuale può essere soggetto a modifiche man mano che l'applicazione viene aggiornata. Per essere sicuri di avere l'ultima versione, consigliamo di scaricarla dal nostro sito web www.scs-sentinel.com

B- SPECIFICHE

B1- Contenuto del kit

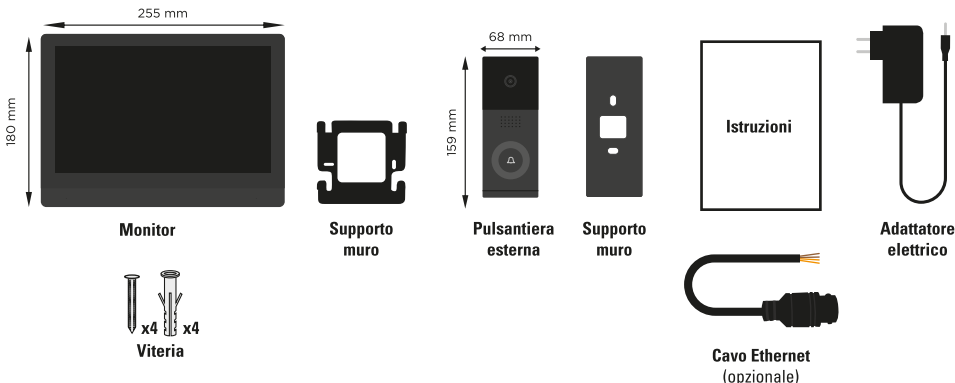

B2- Presentazione del prodotto

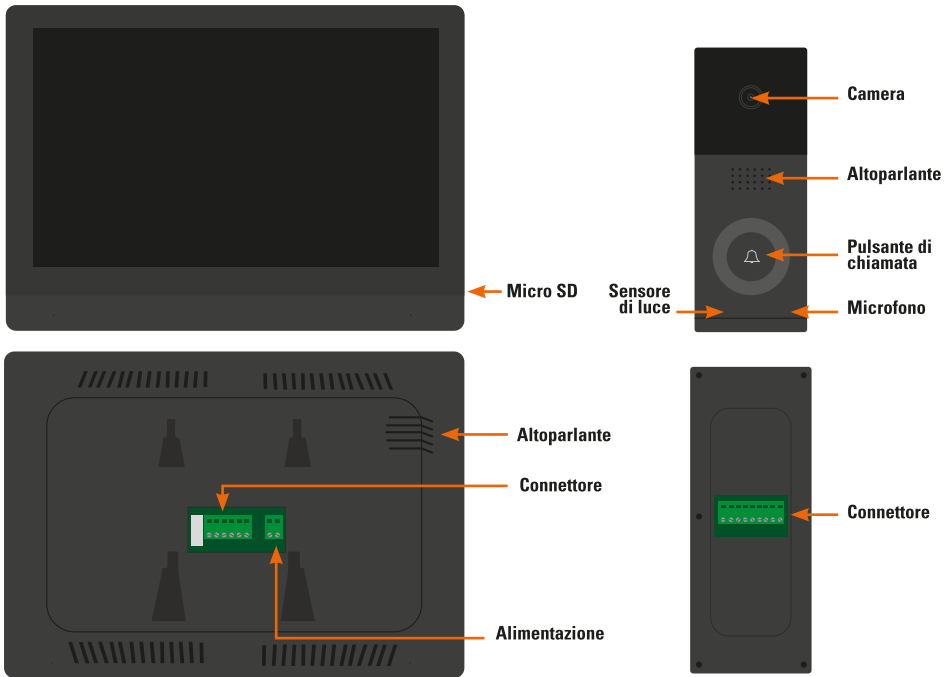

C- CABLAGGIO / INSTALLAZIONE

C1- Installazione

Monitor

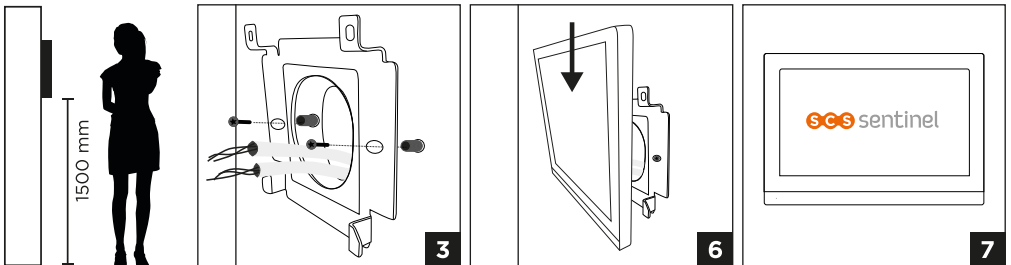

1. Scegliere una posizione adeguata per il monitor.
2. Praticare 2 fori con una distanza corrispondente a quella del supporto a parete, quindi inserire i 2 tasselli in dotazione.. (Le alette di fissaggio devono sporgere verso di voi).
3. Far passare il cavo attraverso il foro della supporto e fissarlo con le 2 viti in dotazione.
4. Spelare i cavi che escono dalla parete per una lunghezza di 10 mm.
5. Collegare i fili secondo lo schema di cablaggio
6. Fissare il monitor al supporto a parete facendolo scorrere verso il basso fino all'arresto.
7. Accendere il monitor per verificare il corretto funzionamento del sistema.

Pulsantiera esterna

Si consiglia l'installazione in un portico o in un'area coperta.
Evitare che l'obiettivo della telecamera entri in contatto diretto con i raggi solari.

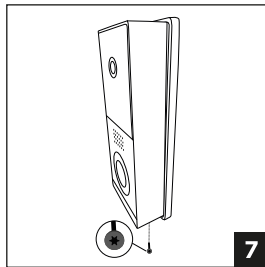
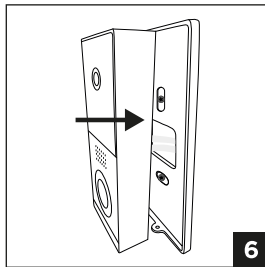
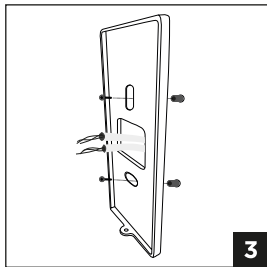
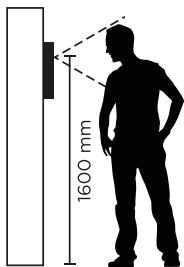

- Scegliere una posizione adeguata per il monitor.
- Praticare 2 fori con una distanza corrispondente a quella del supporto piatto, quindi inserire i 2 tasselli in dotazione.
- Far passare il cavo attraverso il foro del supporto piatto, quindi fissarlo alla parete con le 2 viti in dotazione.
- Spelare i cavi che escono dalla parete per una lunghezza di 10 mm.
- Collegare i fili secondo lo schema elettrico dell'impianto.
- Fissare il posto esterno alla staffa a parete.
- Avvitare la vite di sicurezza nella parte inferiore del posto esterno.

C2- Schema di cablaggio

Senza polarità

0 - 100 m - 0,75 mm²

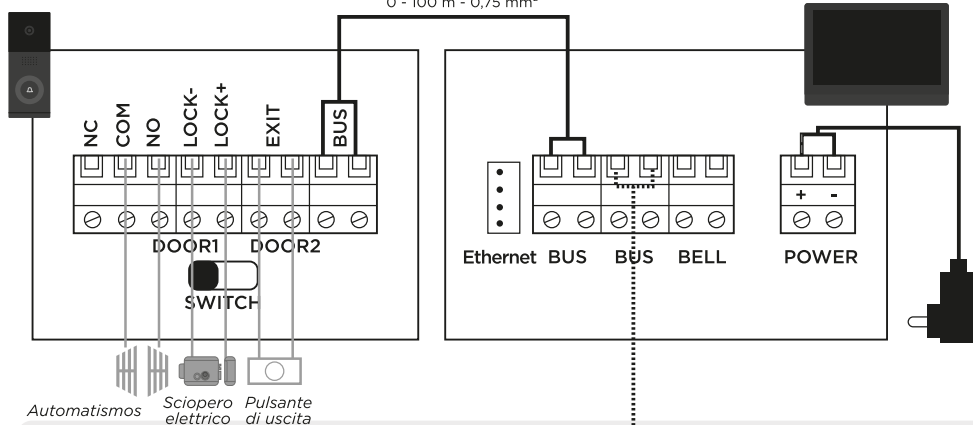

Elementi aggiuntivi

È possibile collegare fino a 6 monitor e 2 posti esterni.

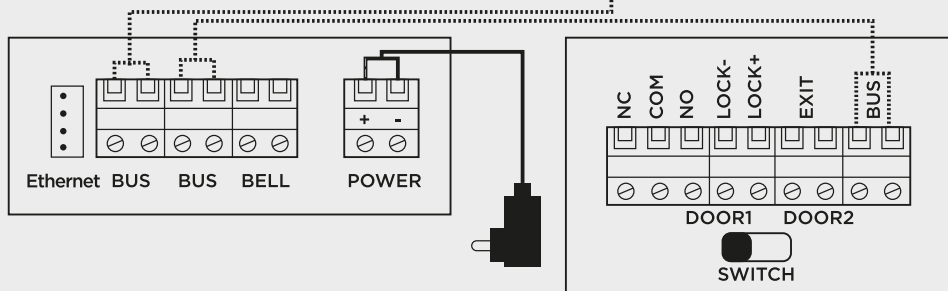

⚠ Se sono installati due altoparlanti per porta, è essenziale posizionare el switch su "porta1" e l'altro switch su "porta2", altrimenti si verificherà un conflitto di indirizzi.

D- UTILIZZO

D1- Chiamata dalla pulsantiera esterna

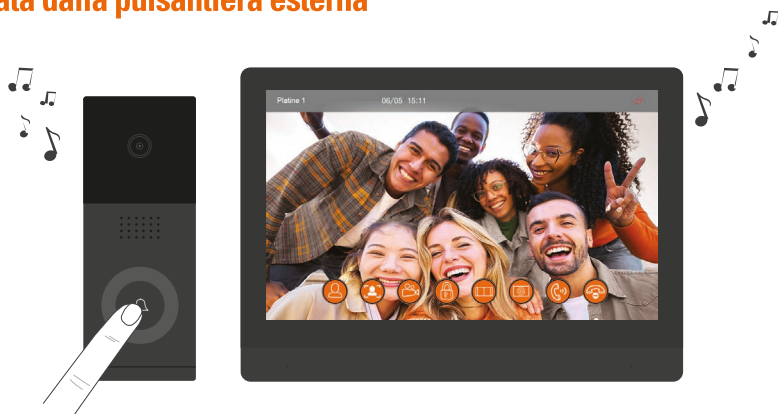

Cambiamento posto esterno



Registrare una foto



Registrare un video (Carte SD)



Apriporta / serratura



Apertura del cancello



Impostazioni schermo / volume / luminosità...



Rispondere (120 sec. max)



Riagganciare
Torna alla schermata iniziale

D2- Schermo principale

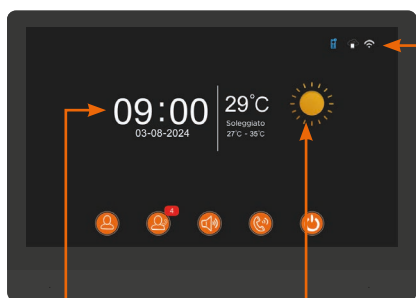

Tempo & data

Tempo
Il monitor visualizza automaticamente le previsioni del tempo se è collegato a Internet.



Pulsantiera esterna collegato



Telefono accoppiato



Wi-Fi collegato



Wi-Fi disconnesso



Monitor
Vista della telecamera



Chiamata
Funzione intercomunicazione tra monitor



Registro chiamate



Standby
Per uscire dalla modalità standby, toccare lo schermo



Silenzioso
Spegne il monitor

Toccare lo schermo per accedere alle impostazioni:

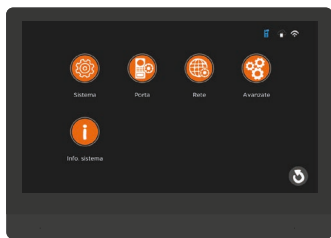

Sistema

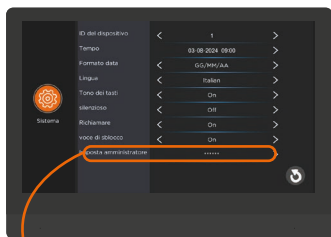

Mode administrateur

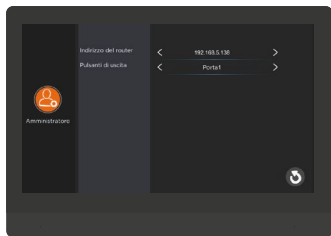

Scegliere l'azione del pulsante di uscita :

- Aprire l'apriporta
- Apertura del cancello
- Aprire entrambi contemporaneamente

Porta

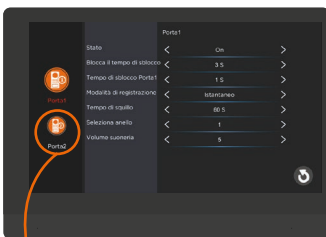

Stato

Se è installato un secondo posto esterno, cambiare lo stato da inattivo > attivo

Rete

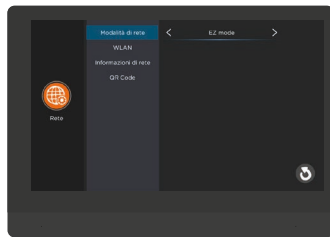

Modalità di accoppiamento

Cavo: connessione Ethernet
Modalità EZ: connessione Wi-Fi

WLAN

Configurazione Wi-Fi

Avanzate

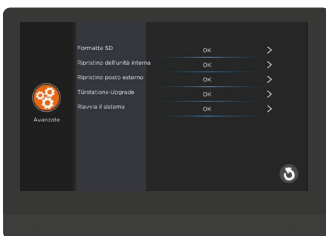

Inizializza monitor / deck :

Questa funzione ripristina tutti i dati e le impostazioni iniziali dell'apparecchio.

Info sistema

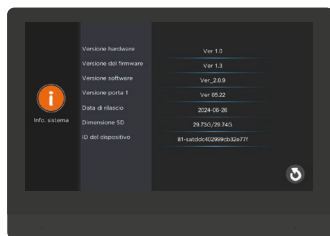

E- CONFIGURAZIONE DELL'APPLICAZIONE

Installazione dell'applicazione



iSCS Sentinel

Per scaricare l'applicazione, effettuare il login da App Store o Play Store del proprio smartphone. Cercare «iSCS Sentinel», poi cliccare su Installare.

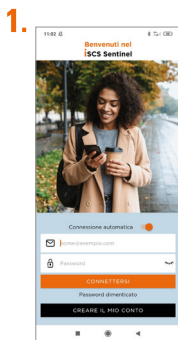

Quando il download è completo, aprire l'applicazione e cliccare su «creare il mio conto».



Inserire l'indirizzo e-mail e la password nelle caselle corrispondenti.

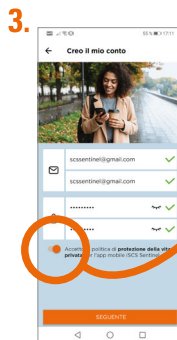

Si prega di accettare l'informativa sulla privacy prima di cliccare su seguente.

Premere il tasto seguente.



Compilare il codice di convalida ricevuto via e-mail. Poi confermare l'account.

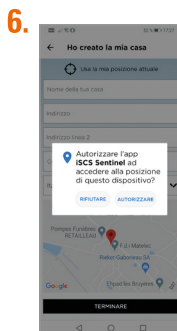
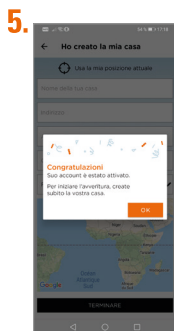

Premere AUTORIZZARE.

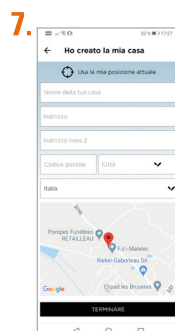

Inserire tutte le informazioni necessarie per creare la propria casa. Poi cliccare su Terminare.

Aggiunta della monitor

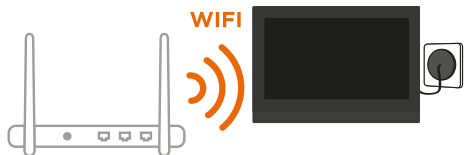

Collegare il monitor all'alimentazione e posizionarlo vicino al router Wi-Fi. Il telefono deve essere collegato alla stessa rete Wi-Fi del monitor e la localizzazione deve essere abilitata.



Alcuni materiali possono ridurre la portata del Wi-Fi.

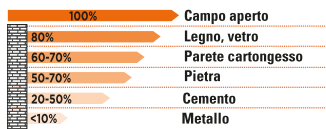

Premere + poi «NUOVO DISPOSITIVO» per aggiungere il prodotto



La rete deve essere in 2,4 GHz per funzionare



Inserire la chiave Wi-Fi, scansionare il codice QR sul retro del monitor o inserire il codice manualmente.



Collegare il monitor e andare in rete, poi in WLAN (inserire le informazioni di connessione), fare clic sul codice QR (scansionare il codice QR visualizzato sul monitor)

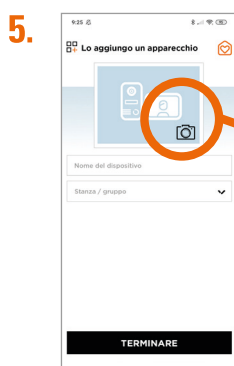

Inserire un nome per del prodotto e la stanza in cui si trova.



Aggiungere una foto del profilo del prodotto, galleria o selezionare un'immagine predefinita (visuale del prodotto o ultima acquisizione del movimento.)

F- IMPOSTAZIONE

Impostazioni dell'applicazione



Premere  per accedere alle impostazioni dell'applicazione.



Visualizza il mio profilo:
Modificare i dati personali se necessario.

Per aggiungere una casa

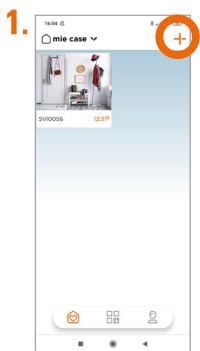

Cliccare 



Creare una nuova casa.

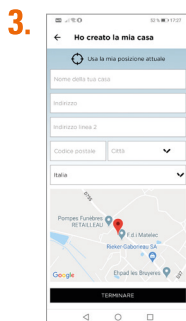

Compilare i campi e premere «TERMINARE».

Per cancellare una casa



Premere 

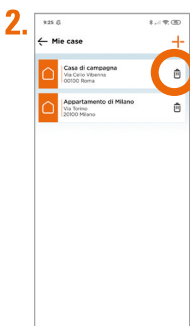

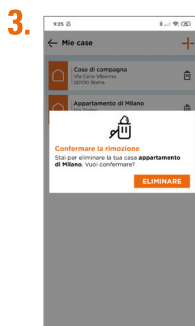

Premere  per cancellare una casa.



Per modificare una casa

- 

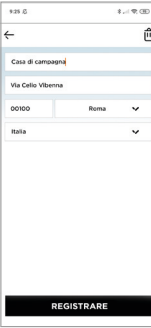

1. Premere 
- 

2. Modificare l'indirizzo.
- 

3.

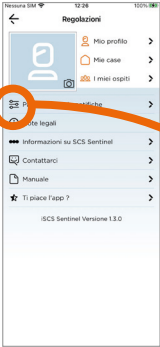
Impostazioni delle notifiche

- 

1. Premere  per accedere alle impostazioni delle notifiche.
- 

2. Premere Attiva notifiche per attivare tutte le notifiche. Altrimenti, premere le notifiche desiderate.

Utilizzo dell'applicazione

- 

1. Premere per parlare.
- 

2. Riprendere la foto nel telefono.
- 

3. Riprendere il video nel telefono.
- 

4. Attivare lo schermo intero (muovere il telefono).
- 

5. Riprendere il video nel telefono.
- 

6. Rilasciare la serratura elettrica.
- 

7. Gestione dei posti esterni.
- 

8. Aprire o chiudere il cancello.

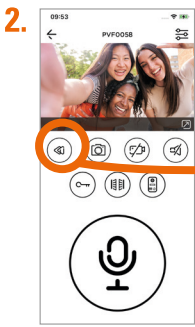

2. **Replay :**
visualizzare cosa
è successo.

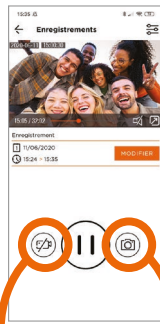

Salvare un
video

Salvare una
foto



3. **Premere**
per
modificare le
impostazioni
del prodotto



Di default, la telecamera
apparirà nell'elenco dei
preferiti non appena
l'applicazione viene
aperta.

Premere 
per aggiungere/rimuovere
la telecamera dai preferiti.

Scenari

Uno scenario è un'azione che segue uno o più eventi scatenanti:

1

Selezionare/ eventi trigger. Se avete parecchi grilletti, voi con la scelta fra combinarli insieme (E) o dissociarli per realizzare l'azione (O).

2

Definiscono/le azioni da eseguire.

3

Salva il tuo copione.

Successivamente, l'applicazione avvierà il/le azioni(e) dello scenario quando avrà individuato un trigger.



Per selezionare
uno o più eventi
di attivazione
(dispositivo, data/
ora o località),
premere +.

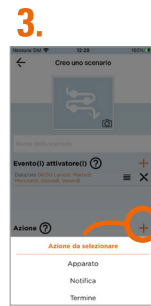

Per selezionare
una o più azioni
(dispositivo,
notifica o ritardo)
premere +.



Di default, lo
scenario apparirà
nella lista dei
preferiti.



● Lo scenario è
attivato.

▶ Attivare le «azioni»
dello scenario
senza attendere gli
«eventi scatenanti».

Aggiungere ospiti

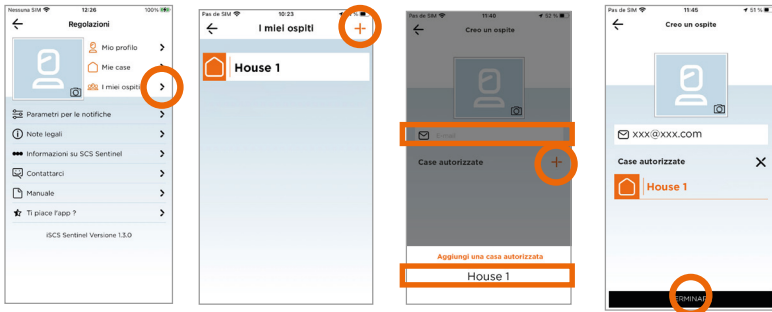

⚠ Tramite l'applicazione iSCS Sentinel, l'ospite può attivare/disattivare i dispositivi ma non può impostarli.

Reset

Per rimuovere completamente la telecamera, è necessario cancellarla nell'applicazione.

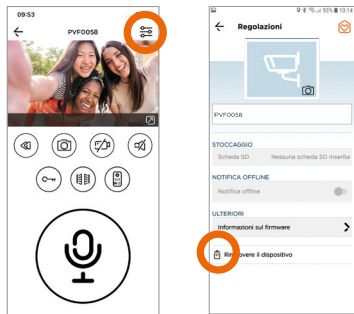

G- CARATTERISTICHE TECNICHE

Monitor

Alimentazione	24V DC 1A 24W
Schermo	Schermo touchscreen 10" TFT LCD
Dimensioni	255 x 180 x 28,5 mm
Risoluzione dello schermo LCD	1024 x 600 px
Salvataggio su scheda SD esterna (foto/video)	4Go - 128 Go classe 4 (non fornite) È necessario formattare la scheda micro SD prima di utilizzarla
Frequenza operativa	2412 MHz - 2472 MHz
Potenza massima di trasmissione	< 100mW
Wi-Fi	802 11b/g/n

Pulsantiera esterna

Alimentazione	23V DC 0,2A
Dimensioni	68 x 159 x 31 mm
Risoluzione HD	1080 x 720 px
Campo di ripresa	110°
Visione notturna	LED a infrarossi
Temperatura di esercizio	-20°C /+ 50°C
Indice de protezione	IP65

Adattatore elettrico

Riferimento del modello	MX24W1-2401000V
Tensione di ingresso	100-240V AC
Frequenza del CA dell'entrata	50/60Hz
Tensione di uscita	24V DC
Corrente di uscita	1A
Potenza di uscita	24W
Rendimento medio in modo attivo	88,29%
Rendimento a basso carico (10%)	84,51%
Consumo elettrico a vuoto	0,084W

Modalità standby

Consumo energetico in modalità standby	3,8W
Tempo di attivazione della modalità standby	15 minuti

H- ASSISTENZA TECNICA

Assistenza telefonica

I tecnici del servizio post-vendita sono disponibili al numero :



 **01119620971**

In caso di alfunzionamento del prodotto durante l'installazione o pochi giorni dopo la stessa si invita a contattare il servizio clienti rimanendo in prossimità del prodotto in modo da consentire ai nostri tecnici di diagnosticare subito l'origine del problema.

Chat online



Una domanda ?

Per una risposta personalizzata, utilizzare la nostra chat online su nostro sito web www.scs-sentinel.com

I- GARANZIA



SCS Sentinel concede a questo prodotto una garanzia superiore alla durata legale, in garanzia di qualità e affidabilità.

È obbligatorio conservare una prova d'acquisto per tutta la durata della garanzia.

Conservare accuratamente sia il codice a barre che lo scontrino :
vi saranno richiesti per far valere la garanzia.

J- AVVERTENZE

- Mantenere una distanza minima (10 cm) intorno al dispositivo per una sufficiente aerazione.
- Non ostacolare l'aerazione ostruendo le prese d'aria con oggetti come giornali, tovaglie, tende, ecc.
- Non avvicinare l'apparecchio a fiamme libere, come quelle delle candele accese.
- Il normale funzionamento del prodotto può essere disturbato da una forte interferenza elettromagnetica.
- Questa attrezzatura è destinata esclusivamente ad uso privato.
- Il monitor e il suo adattatore non devono essere esposti a gocce o spruzzi d'acqua. Non si devono appoggiare su questa apparecchiatura oggetti pieni di liquidi, come ad esempio vasi.
- La presa della rete di alimentazione deve rimanere facilmente accessibile. Viene utilizzata come dispositivo di spegnimento.
- Il monitor e l'adattatore devono essere utilizzati all'interno.
- Eseguire tutti i collegamenti tra gli elementi prima di alimentare il kit.
- Collegare il dispositivo solo con l'adattatore in dotazione.
- Gli elementi elettronici devono essere maneggiati con attenzione.
- Non tappare il microfono della piastra esterna e del monitor.
- Durante l'installazione, gli imballaggi non devono essere lasciati alla portata di bambini o animali, poiché costituiscono una potenziale fonte di pericolo.
- Questo prodotto non è un giocattolo. Non è stato progettato per essere utilizzato dai bambini.

 Prima di ogni eventuale manutenzione, scollegare i dispositivi. Non pulire il prodotto con solventi, sostanze abrasive o corrosive. Per pulire lo schermo del monitor, servirsi di un semplice panno morbido. Non spruzzare niente sul prodotto.

 Verificare la buona manutenzione del prodotto e controllare frequentemente l'impianto per individuare ogni eventuale segno di usura. Non utilizzare il dispositivo se sono necessarie riparazioni o regolazioni. Rivolgersi a personale qualificato.

 Non gettare gli apparecchi fuori uso insieme ai normali rifiuti domestici. Potrebbero contenere sostanze pericolose capaci di nuocere alla salute e all'ambiente. Utilizzare i mezzi per la raccolta differenziata messi a disposizione dal comune o dal proprio distributore.

 Corrente continua  Corrente alternata  Modello di classe II

 Il monitor e l'adattatore è destinato esclusivamente all'uso interno



IP 65 : L'unità esterna è protetta da polvere e getti d'acqua provenienti da tutte le direzioni.

K- DICHIARAZIONE UE DI CONFORMITÀ

Con la presente, SCS Sentinel certifica che il prodotto é conforme alle esigenze essenziali applicabili e in particolare alle esigenze della direttiva 2014/53/UE. La dichiarazione UE di conformità completa può essere consultata sul sito web: www.scs-sentinel.com/downloads.

ÍNDICE

A- Precauciones para el uso	42
B- Descripción	42
C- Cableado / Instalación	43
D- Uso	45
E- Configuración	47
F- Ajuste	49
G- Características técnicas	53
H- Asistencia técnica	54
i- Avisos	54
J- Garantía	54
K- Declaración de conformidad	55

A- PRECAUCIONES PARA EL USO

Este manual forma parte de su producto. Se facilitan la siguientes instrucciones para su seguridad. Leer detenidamente estas instrucciones antes de utilizar el producto y conservarlas para futuras consultas. Elegir un emplazamiento adecuado. Asegurarse de que ningún elemento dificulte la sujeción de los tacos y tornillos en la pared. Terminar y controlar su instalación antes de enchufar. No enchufar su alimentación mientras su instalación no esté terminada y controlada. La instalación, las conexiones eléctricas y los ajustes deben efectuarse por una persona calificada y especializada. El bloque de alimentación debe instalarse en un lugar seco. Usar el equipo únicamente para el fin para el que ha sido diseñado.

La función de este videoteléfono es identificar a un visitante, no debe utilizarse para vigilancia callejera. La utilización de esta instalación debe ser conforme a la ley francesa n° 78-17 del 6 de enero de 1978 relativa a la informática, a los ficheros y a las libertades. Corresponde al comprador informarse en la CNIL sobre las condiciones y autorizaciones administrativas necesarias para una utilización fuera de un contexto estrictamente personal. SCS Sentinel no podrá ser considerada responsable en caso de utilización de este producto fuera de las leyes y reglamentos en vigor.

Este producto sólo funciona con la aplicación iSCS Sentinel. La aplicación está disponible de forma gratuita en PlayStore y AppStore. Actualizaciones pueden ser necesarias, por ejemplo, para corregir errores, mejorar funciones o la experiencia del usuario. Puede activar o desactivar las actualizaciones automáticas para la aplicación iSCS Sentinel en la configuración de PlayStore o AppStore. La información relativa al motivo de la actualización, su impacto en el rendimiento y la evolución de las funcionalidades del producto o aplicación, así como el espacio de almacenamiento utilizado, se indican, para cada actualización en PlayStore o AppStore.

De acuerdo con la normativa y la garantía legal, se garantizan la disponibilidad y actualizaciones de la aplicación durante 2 años. **Este manual puede estar sujeto a cambios en función de las actualizaciones de la aplicación. Para asegurarse de que tiene la última versión, le aconsejamos que la descargue de nuestro sitio web www.scs-sentinel.com o de la aplicación iSCS Sentinel : ajustes / manuales.**

B- DESCRIPCIÓN

B1- Contenido / dimensiones

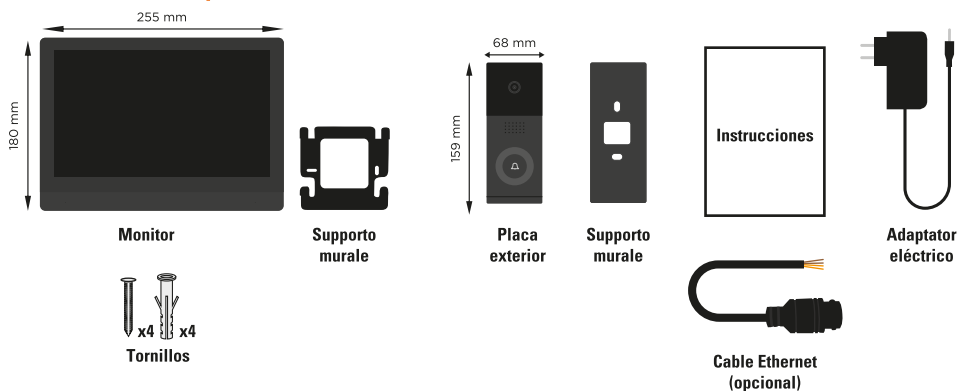

B2- Presentación del producto

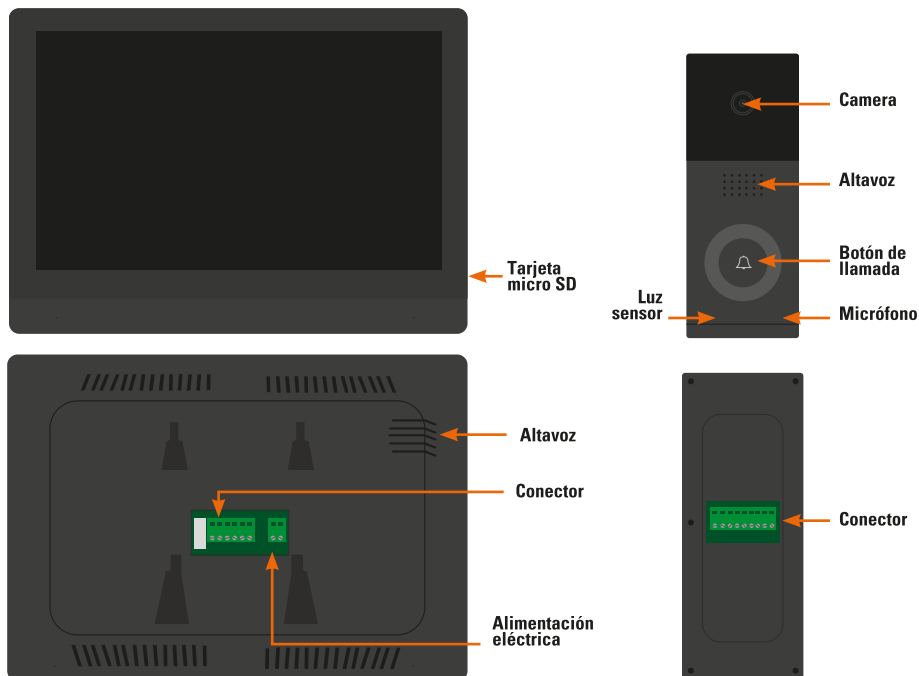

CABLEADO / INSTALACIÓN

C1- Instalación

Monitor

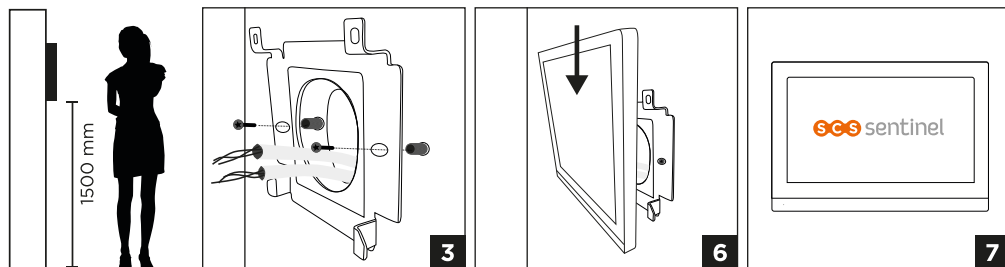

1. Elegir una ubicación adecuada para el monitor.
2. Taladrar 2 orificios con una distancia correspondiente a la distancia de los orificios del soporte mural, e insertar los 2 tacos suministrados. (Las lengüetas de fijación deben sobresalir hacia usted.)
3. Pasar el cable por el orificio del soporte y fijarlo con los 2 tornillos suministrados.
4. Pelar los cables que salen de la pared hasta una longitud de 10 mm.
5. Conectar los cables de acuerdo con el esquema eléctrico.
6. Fijar el monitor al soporte de pared deslizándolo hacia abajo hasta el tope.
7. Encender el monitor para comprobar que el sistema funciona correctamente.

Placa exterior

Se recomienda la instalación en una zona cubierta.

Evitar que el objetivo de la cámara entre en contacto directo con los rayos del sol.

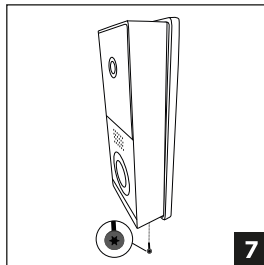
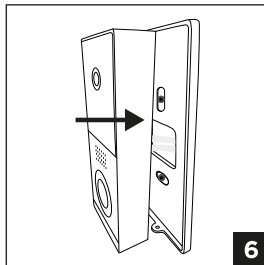
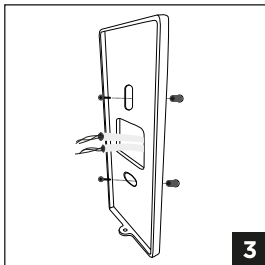
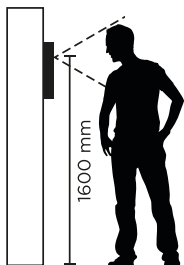

1. Scegliere una posizione adeguata per il monitor.
2. Taladrar 2 orificios a la misma distancia que los del soporte mural e introducir los 2 tacos suministrados.
3. Pasar el cable con una distancia correspondiente a la del soporte mural y fijarlo a la pared con los 2 tornillos suministrados.

4. Pelar los cables que salen de la pared hasta una longitud de 10 mm.
5. Conectar los cables según el esquema eléctrico.
6. Fijar la placa de calle al soporte mural

7. Atornillar el tornillo de seguridad situado en la parte inferior de la estación de puerta.

C2- Esquema de cableado

Sin polaridad

0 - 100 m - 0,75 mm²

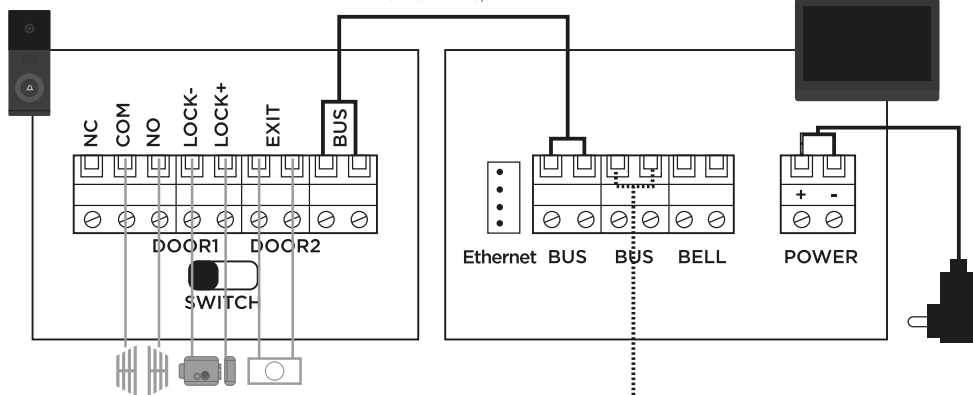

Elementos adicionales

Se pueden conectar hasta 6 monitores y 2 estaciones de puerta.

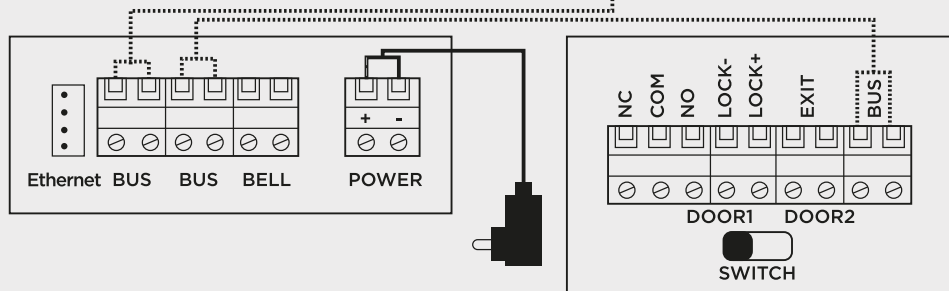

⚠ Si se instalan dos altavoces de puerta, es imprescindible colocar el switch en «puerta1» y el otro switch en «puerta2», de lo contrario se producirá un conflicto de direcciones.

D- USO

D1- Llamada desde la placa exterior

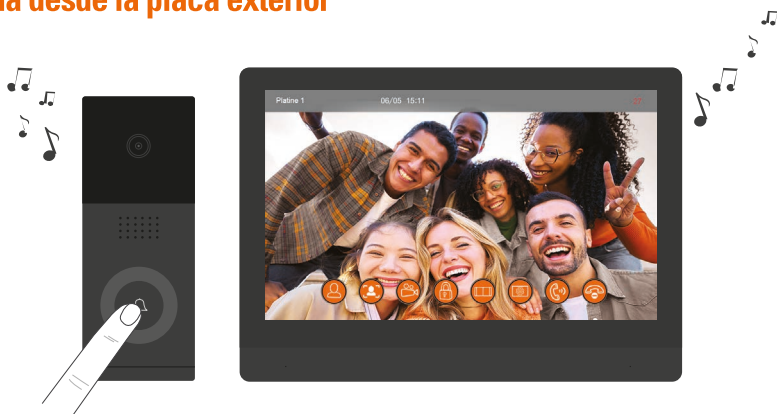

Cambiar estación de puerta



Capturar una foto



Capturar un vídeo (Tarjeta SD)



Apertura cerradura / Serradura



Apertura del portal / cancela



Ajustes pantalla / volumen / brillo...



Recoger (120 sec. max)



Colgar Volver a la pantalla principal

D2- Pantalla principal

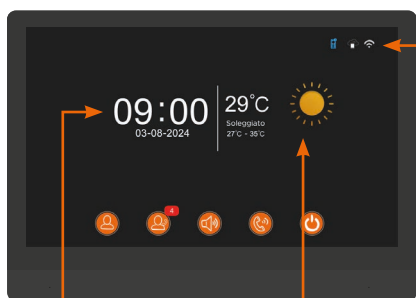

Hora y fecha

El tiempo
El monitor muestra automáticamente la previsión meteorológica si está conectado a Internet



Estación de puerta conectado



Teléfono emparejado



Wi-Fi conectado



Wi-Fi desconectado



Monitor
Vista de cámara



Llamada
Función intercomunicación entre monitores



Registro de llamadas



Standby
Para salir del modo de espera, toque la pantalla



Silencio
Apaga el monitor

Toca la pantalla para acceder a los ajustes:

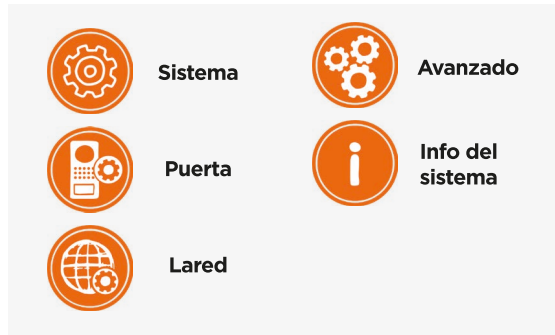
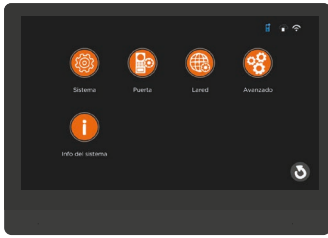

Sistema

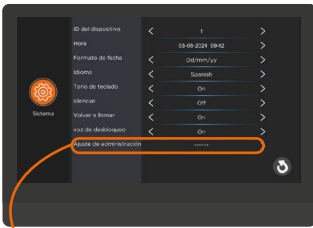

Modo administrador

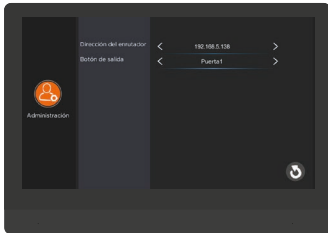

Elija la acción del botón de salida :
 Abrir la huelga
 Apertura de la puerta
 Abrir las dos a la vez

Puerta

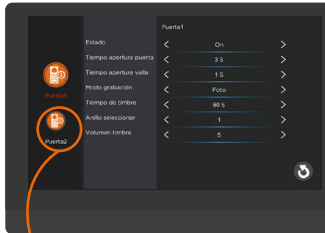

Estado
 Si hay instalada una segunda estación de puerta, cambie el estado de inactivo > activo

Lared

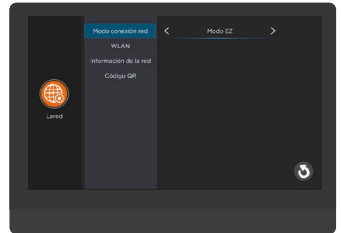

Modo de emparejamiento
 Cable: conexión ethernet
 Modo EZ: conexión Wi-Fi

WLAN
 Configuración Wi-Fi

Avanzado

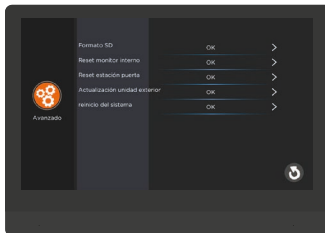

Inicializar monitor / deck :
 Esta función restaura todos los datos y ajustes iniciales del dispositivo.

Infos sistema



E- CONFIGURACIÓN DE LA APLICACIÓN

Instalación de la aplicación



iSCS Sentinel

Descargar la aplicación en la App Store o Play Store del smartphone. Buscar «iSCS Sentinel» y hacer clic en Instalar.



Al final de la descarga, abrir la aplicación y hacer clic en crear mi cuenta



Introducir la dirección de correo electrónico y la contraseña en las casillas correspondientes.

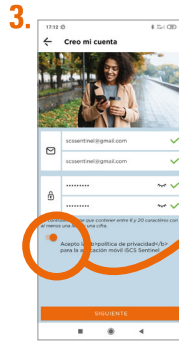

Aceptar la política de privacidad antes de hacer clic en siguiente

Pulsar «siguiente».



Introducir el código de validación que ha recibido por correo electrónico. Luego, validar la cuenta.

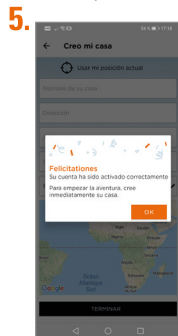

Pulsar AUTORIZAR.



Introducir toda la información necesaria para crear la casa. Luego, hacer clic en terminar.

Añadir la cámara

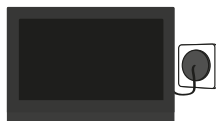

Enchufar la fuente de alimentación del monitor y colocarlo cerca del router Wi-Fi. El teléfono debe estar conectado a la misma red Wi-Fi que el monitor y la localización debe estar activada.



Algunos materiales pueden reducir el alcance de la red Wi-Fi.

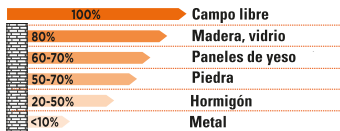

Pulsar **+** y luego «NUEVO DISPOSITIVO» para añadir el producto.



La red debe estar en **2.4 GHz** para funcionar.



Introducir la clave Wi-Fi, escanear el código QR de la parte trasera del monitor o introducir el código manualmente.



Conecte el monitor y acceda a la red, luego a WLAN (ingrese su información de conexión), haga clic en el código QR (escanee el código QR que se muestra en el monitor).

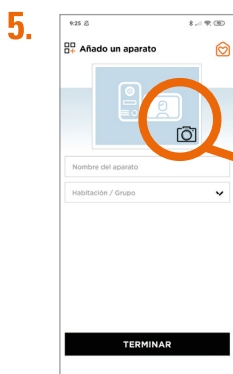

Introducir un nombre para el videoportero y la sala donde se encuentra el producto.



Añadir una foto de perfil desde la cámara, la galería o seleccionar una imagen predeterminada (foto de producto o última captura de movimiento).

F- AJUSTE

Ajustes de la aplicación

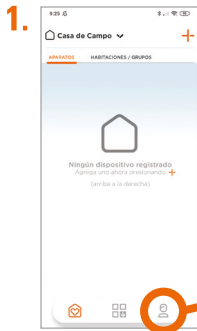

Pulsar  para acceder a los ajustes de la aplicación.



Ver mi perfil:
Modificación de las informaciones personales

Para añadir una casa

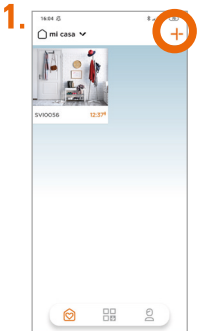

Hacer clic en 

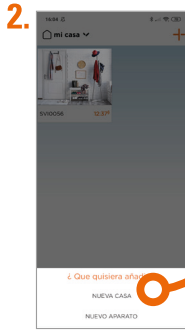

Crear una nueva casa.

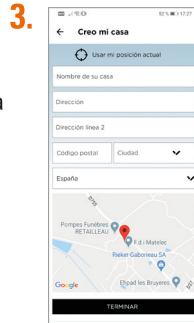



Rellenar los campos y pulsar **TERMINAR**.

Para suprimir una casa

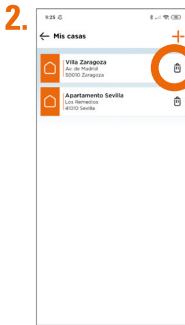

Pulsar 



Pulsar  para eliminar una casa.

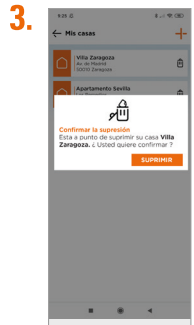

Para modificar una casa



- 

Pulsar 
- 

Modificar la dirección.
- 

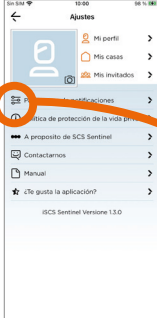
Configuración de las notificaciones

- 

Pulsar  para acceder a la configuración de las notificaciones.
- 

Pulsar «Activar notificaciones» para activar todas las notificaciones. De lo contrario, pulsar sólo las notificaciones deseadas.

Uso de la aplicación

- 

Pulsar para hablar.
- 

Captura de fotografías en el teléfono.

Activar la pantalla completa (girar el teléfono).

Captura de video en el teléfono.
- 

Liberar la cerradura

Gestión de estaciones placa exterior

Abrir o cerrar el portal

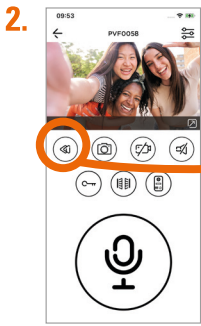

2. **Replay :**
Ver lo que pasó

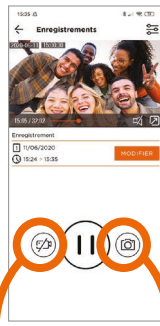

Grabar un video

Grabar una foto



3. Pulsar  para modificar la configuración del producto.



Por defecto, el producto aparecerá en la lista de favoritos al abrir la aplicación.

Pulsar  para agregar/suprimir el producto de los favoritos.

Escenario

Un escenario es una acción que sigue a un evento o eventos desencadenantes:

1.

Selecione/los eventos desencadenantes. Si tiene varios disparadores, puede elegir entre combinarlos (Y) o separarlos para realizar la acción (O).

2.

Defina el/ las acciones a realizar.

3.

Registrar su escenario.

A continuación, la aplicación ejecutará la/ las acciones (s) del escenario una vez que haya detectado un disparador.

SIGUIENTE



2. Para seleccionar uno o varios eventos de activación (dispositivo, fecha/hora o ubicación), pulsar +.

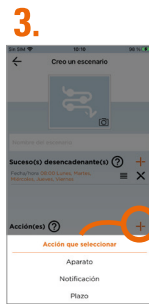



3. Para seleccionar una o varias acciones (dispositivo, notificación o retardo) pulsar +.



4. Por defecto, el escenario aparecerá en la lista de favoritos.



 El escenario se activa

 Activar las «acciones» del escenario sin esperar a los «eventos desencadenantes».

Para añadir invitados

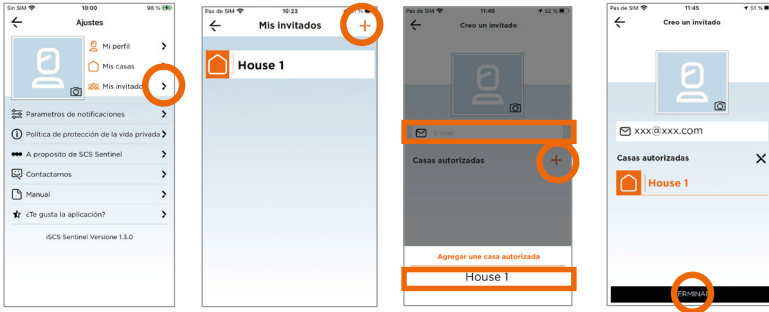

⚠ A través de la aplicación iSCS Sentinel, el invitado puede activar/desactivar los dispositivos pero no puede configurarlos.

Reset

Para eliminar el dispositivo por completo, hay que eliminarlo en la aplicación.

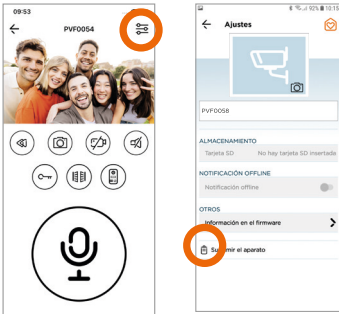

G- CARACTERÍSTICAS TÉCNICAS

Monitor

Alimentación	24V DC 1A 24W
Pantalla	Pantalla táctil 10" TFT LCD
Dimensiones	255 x 180 x 28,5 mm
Resolución de pantalla LCD	1024 x 600 px
Copia de seguridad en tarjeta SD externa (foto y videos)	4 Go - 128 Go clase 4 (no suministrada) Es necesario formatear la tarjeta micro SD antes de utilizar
Frecuencia de funcionamiento	2412 MHz - 2472 MHz
Potencia máxima de transmisión	< 100mW
Wi-Fi	802 11b/g/n

Placa exterior

Alimentación	23V DC 0,2A
Dimensiones	68 x 159 x 31 mm
Resolución HD	1080 x 720 px
Ángulo de visión	110°
Visión nocturna	LED IR
Temperatura de servicio	-20°C /+ 50°C
Índice de protección	IP65

Adaptador

Referencia del modelo	MX24W1-2401000V
Tensión de entrada	100-240V AC
Frecuencia de CA de entrada	50/60Hz
Tensión de salida	24V DC
Corriente de salida	1A
Potencia de salida	24W
Rendimiento medio en activo	88,29%
Rendimiento bajo carga (10%)	84,51%
Consumo eléctrico sin carga	0,084W

Modo de espera

Consumo de energía en modo de espera	3,8W
Tiempo hasta entrar en modo de espera	15 minutos

H- ASISTENCIA TÉCNICA

Consejos de los expertos

Los técnicos del servicio posventa están disponibles en el siguiente número:



937376105

Si el producto funciona mal durante la instalación o pocos días después, basta con ponerse en contacto con el servicio de atención al cliente permaneciendo cerca del producto para que nuestros técnicos puedan diagnosticar el problema inmediatamente.

Chat' en ligne



Una pregunta ?

Para una respuesta personalizada, se puede utilizar nuestro chat en línea en nuestro sitio web www.scs-sentinel.com

I- GARANTÍA



SCS Sentinel concede a este producto una garantía superior a la duración legal, como referencia de calidad y fiabilidad.

Conservar el recibo de compra durante todo este periodo de garantía.

Conservar el código de barra así como que su justificante de compra, serán necesarios para hacer uso de la garantía.

J- AVISOS

- Mantener una distancia mínima de 10 cm alrededor del aparato para asegurar una ventilación suficiente.
- La ventilación no se debe obstaculizar cubriendo las aperturas de ventilación con elementos como por ejemplo periódicos, manteles, cortinas, etc.
- No colocar el aparato cerca de llamas vivas, como velas encendidas.
- Importantes interferencias electromagnéticas pueden perturbar el funcionamiento normal del producto.
- El producto sólo está destinado al uso privado.
- El monitor y su adaptador no deben exponerse a goteos ni salpicaduras de agua. No deben colocarse objetos llenos de líquido, como jarrones, encima de este equipo.
- La toma de corriente debe mantenerse fácilmente accesible. Se usa como mecanismo de desconexión.
- El monitor y el adaptador sólo se pueden usar en interiores.
- Efectuar todas la conexiones entre los elementos antes de enchufar el kit.
- Exclusivamente conectar el equipo con el adaptador incluido.
- Manejar los elementos con cuidado. Los componentes electrónicos son frágiles.
- No obstaculizar el micrófono de la placa exterior o del monitor.
- Durante la instalación del producto, dejar el producto y el embalaje fuera del alcance de los niños o de los animales. Constituyen una fuente potencial de peligro.
- Este producto no es un juguete. No fue diseñado para ser utilizado por niños solos.

 Desconectar el cable de alimentación antes de realizar la limpieza o el mantenimiento. No se debe limpiar el producto con sustancias abrasivas o corrosivas. Utilizar un simple paño suave. No se debe vaporizar ningún producto sobre el aparato.

 Asegurarse de efectuar un correcto mantenimiento del producto y verificar a menudo la instalación para detectar algún posible defecto. No se debe utilizar el aparato si necesita una reparación o un ajuste. Llamar a un personal calificado.

 No se deben tirar los aparatos inservibles con los residuos domésticos, ya que las sustancias peligrosas que puedan contener pueden perjudicar la salud y al medio ambiente. Pídale a su distribuidor que los recupere o utilizar los medios de recogida selectiva puestos a disposición por el ayuntamiento.

 Corriente continua

 Corriente alterna

 Modelo de clase II

 El monitor y el adaptador es sólo para uso en interiores

IP 65 : La unidad exterior está protegida contra el polvo y los chorros de agua procedentes de todas las direcciones.

K- DECLARACIÓN DE CONFORMIDAD



Por la presente, SCS Sentinel declara que este producto cumple con los requisitos esenciales y otras disposiciones relevantes de la directiva 2014/53/UE. La declaración de conformidad completa se puede consultar en el sitio web : www.scs-sentinel.com/downloads.

RESUMO

A- Precauções de utilização	2
B- Descrição.....	2
C- Cablagem / Instalação	3
D- Utilização.....	5
E- Configuração da aplicação.....	7
F- Definições	9
G- Características técnicas.....	12
H- Assistência técnica	13
I- Garantia	14
J- Avisos	14
K-Declaração de conformidade.....	14

A- PRECAUÇÕES DE UTILIZAÇÃO

Este manual é parte integrante do seu produto. Estas instruções são para sua segurança. Leia-as atentamente antes da utilização e guarde-as para consulta posterior. Escolha uma localização adequada. Certifique-se de que nenhum elemento é danificado ao inserir as buchas e parafusos na parede. Não ligue a alimentação antes de a instalação estar totalmente terminada e verificada. A entrada em funcionamento, as ligações elétricas e as regulações devem ser feitas de acordo com as regras definidas e realizadas por uma pessoa qualificada e especializada. O bloco de alimentação deve ser instalado num local seco. Certifique-se de que o produto é usado apenas para a utilização a que se destina. A função deste videofone é identificar um visitante, não deve ser utilizado para vigilância de rua. A utilização desta instalação deve estar em conformidade com a lei francesa n° 78-17, de 6 de Janeiro de 1978, relativa ao tratamento de dados, ficheiros e liberdades. Cabe ao comprador perguntar à CNIL sobre as condições e autorizações administrativas necessárias para a utilização fora de um contexto estritamente pessoal. A SCS Sentinel não pode ser responsabilizada em caso de utilização deste produto fora das leis e regulamentos em vigor.

Este produto funciona apenas com a aplicação iSCS Sentinel. A aplicação está disponível gratuitamente na PlayStore e na AppStore. Poderá ser necessário atualizar a aplicação, por exemplo para corrigir bugs, melhorar funcionalidades e beneficiar de uma melhor experiência do utilizador. Pode ativar ou desativar o caráter automático das atualizações da aplicação iSCS Sentinel nas definições da PlayStore ou da AppStore. As informações relativas ao motivo da atualização, ao seu impacto no desempenho e na evolução das funcionalidades do produto ou da aplicação, bem como o espaço de armazenagem utilizado, encontram-se indicados, para cada atualização, na PlayStore ou na AppStore.

Nos termos da regulamentação e da garantia legal, a disponibilidade da aplicação e respetivas atualizações é garantida por 2 anos.

Estas instruções poderão evoluir de acordo com as atualizações da aplicação. De modo a garantir de que tem a última versão, aconselhamos que a transfira no nosso site www.scs-sentinel.com

B- DESCRIÇÃO

B1- Conteúdo do kit

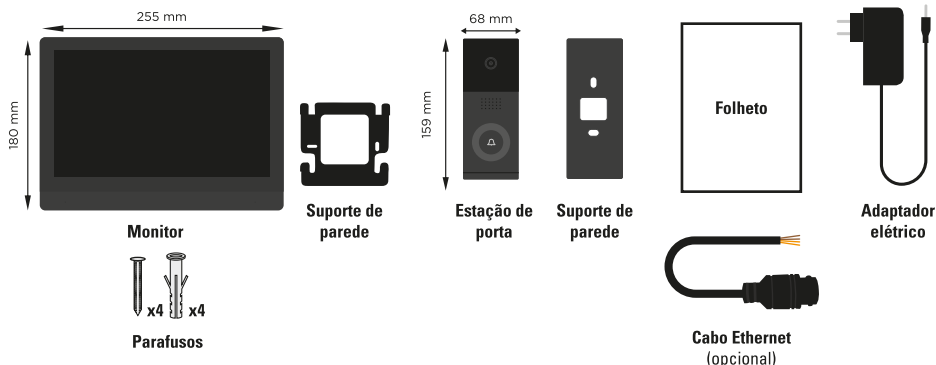

B2- Apresentação do produto

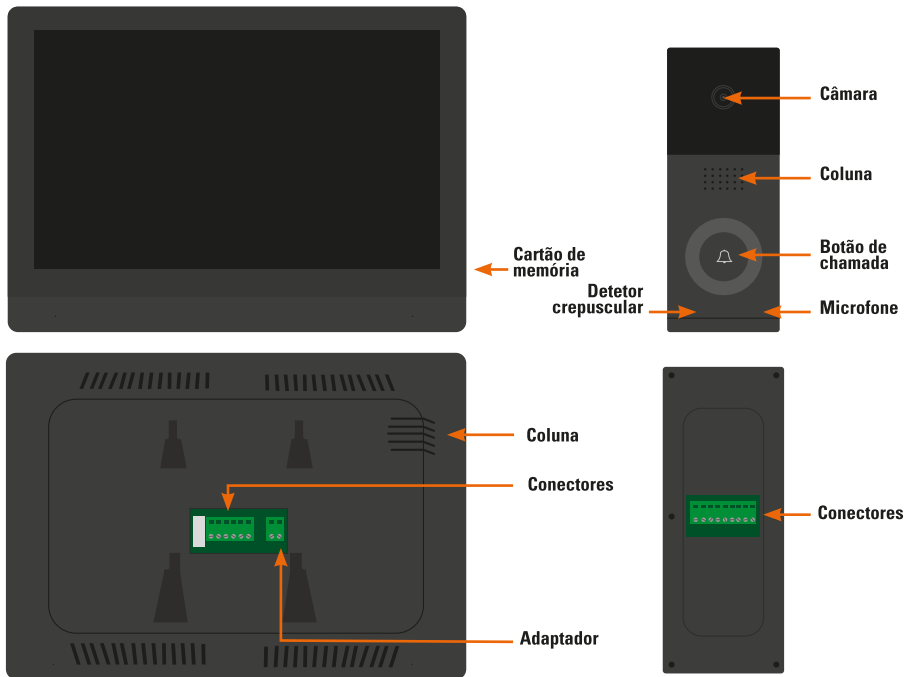

C- CABLAGEM / INSTALAÇÃO

C1- Instalação

Monitor

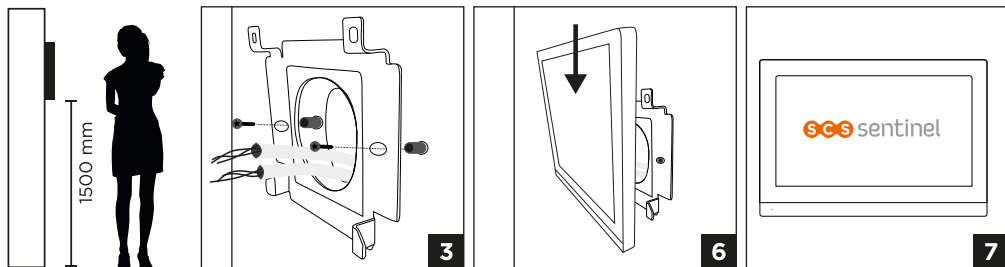

1. Escolher um local adequado para o monitor.
2. Faça 2 furos espaçados para corresponder aos furos do suporte de parede e, em seguida, insira as 2 buchas fornecidas.
(Os olhais de fixação devem estar virados para si).
3. Passe o cabo pelo orifício do suporte e fixe-o com os 2 parafusos fornecidos.
4. Descarte os cabos que saem da parede com um comprimento de 10 mm.
5. Ligar os fios de acordo com o diagrama de cablagem.
6. Fixe o monitor ao suporte de parede, fazendo-o deslizar para baixo até ao limite.
7. Ligue o monitor para verificar se o sistema está a funcionar corretamente.

Módulo exterior

Recomenda-se a instalação num alpendre ou numa área coberta.
Evite que a lente da câmara entre em contacto direto com os raios solares.

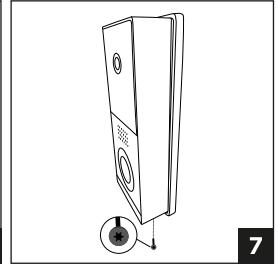
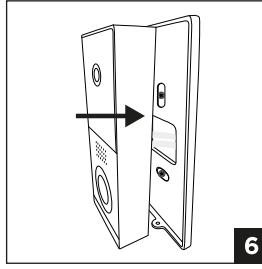
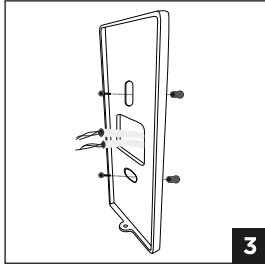
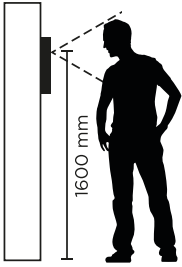

- Escolha um local adequado para instalar a estação de porta.
- Faça 2 furos espaçados para coincidir com o suporte de parede e, em seguida, insira as 2 buchas fornecidas.
- Passo o cabo pelo orifício do suporte e fixe-o com os 2 parafusos fornecidos.
- Descarne os cabos que saem da parede com um comprimento de 10 mm.
- Ligar os fios de acordo com o diagrama de cablagem.
- Fixe a estação de porta ao suporte de parede.
- Aparafusar o parafuso de segurança na parte inferior da estação da porta.

C2- Esquema de ligações Sem polaridade

0 - 100 m - 0,75 mm²

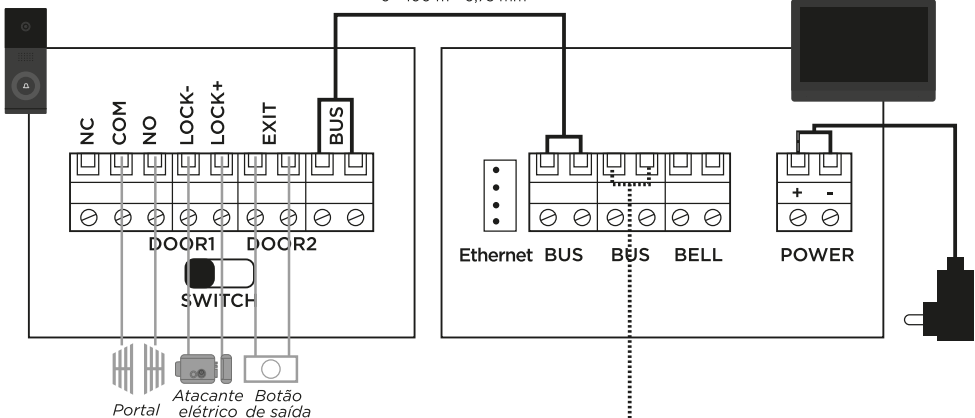

Elementos adicionais

Podem ser ligados até 6 monitores e 2 porteiros automáticos.

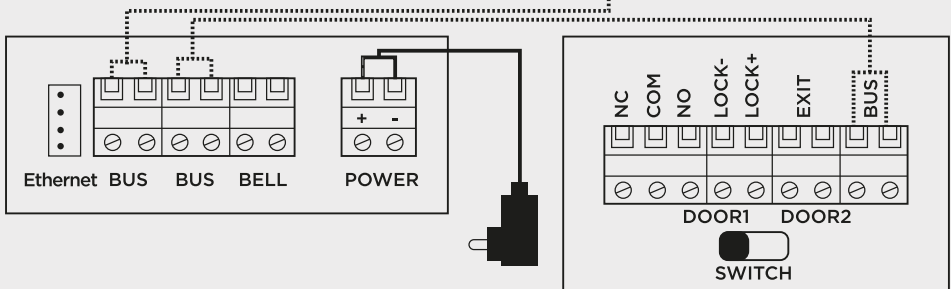

⚠ Se estiverem instalados dois altifalantes de porta, é essencial colocar o switch na "porta1" e o outro switch na "porta2", caso contrário haverá um conflito de endereços.

D- UTILIZAÇÃO

D1- Chamada a partir do módulo exterior

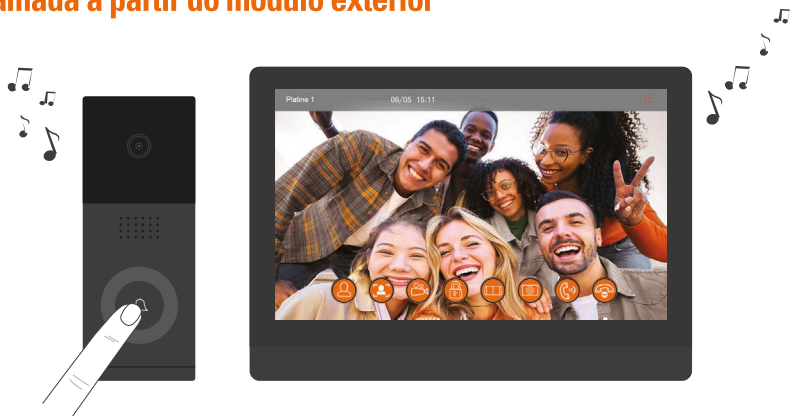

Alterar estação de porta



Registar uma fotografia



Gravar um vídeo (cartão SD)



Abertura placa de fecho / fechadura



Abertura do portão



Definições ecrã / volume / luminosidade...



Recolher (120 sec. max)



Desligar
Voltar à página inicial

D2- Ecrãs principais

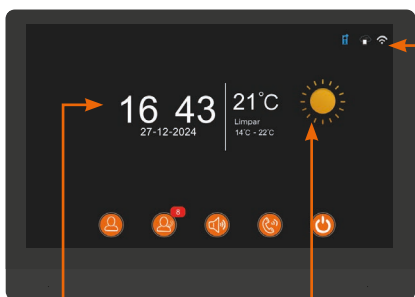

Hora e data

Tempo
O monitor apresenta automaticamente a previsão meteorológica se estiver ligado à Internet



Platina ligado



Telefone emparelhado



Wi-Fi ligado



Wi-Fi desligado



Módulo
Vista da a câmara



Chamada
Função intercomunicação entre monitores



Registo chamadas



Modo de espera
Para sair do modo de espera, toque no ecrã



Silenciador
Desliga o monitor

Toque no ecrã para aceder às definições:

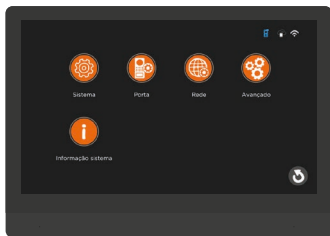

Sistema

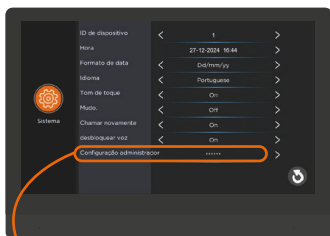

Admin

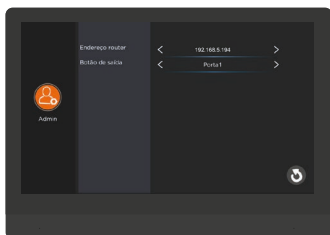

Botão de saída
Abrir portão / porta / ambos ao mesmo tempo

Porta



Estado
Se estiver instalado um segundo posto de controlo de portas, alterar o estado de inativo > ativo

Rede

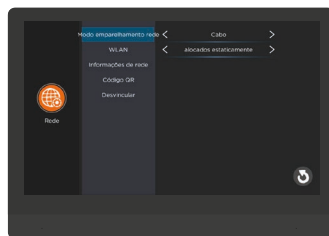

Modo de emparelhamento
Cabo: ligação ethernet
Modo EZ: ligação Wi-Fi

WLAN
Configuração Wi-Fi

Avançado

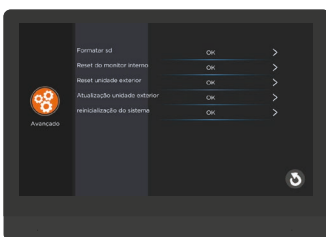

Inicializar o monitor/placa :
Esta função repõe todos os dados e definições iniciais do aparelho.

Informação sistema



E- CONFIGURAÇÃO DA APLICAÇÃO

Instalação da aplicação



iSCS Sentinel

Para transferir a aplicação, vá à App Store ou à Play Store do seu smartphone. Pesquisar «iSCS Sentinel», clicar de seguida em Instalar.

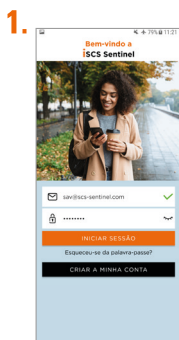

Quando terminar a transferência a aplicação e abrir a aplicação e clicar em criar a minha conta.



Introduzir o endereço de e-mail bem como a palavra-passe nas casas correspondentes.



Pressionar «seguinte».



É necessário aceitar a política de confidencialidade antes de clicar em seguinte.



Introduzir o código de validação recebido por e-mail. Validar de seguida a conta

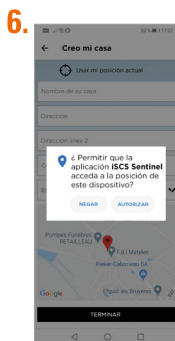
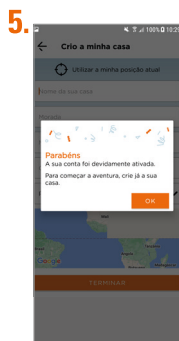

Pulsar «AUTORIZAR».

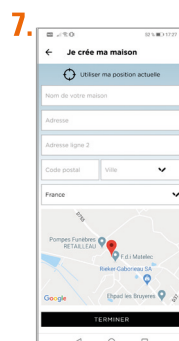

Introduzir todas as informações solicitadas para criar a casa. Clicar, de seguida, em terminar.

Adicionar o produto



Ligar a fonte de alimentação do monitor e colocá-lo próximo do router Wi-Fi. O telefone deve estar ligado à mesma rede Wi-Fi do módulo e a localização tem de estar ativada.



Certos materiais podem reduzir o alcance do sinal Wi-Fi.

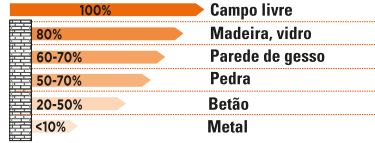

Pressionar **+ NOVO DISPOSITIVO** para adicionar o produto



A rede deve estar em **2.4 GHz** para funcionar.



Introduzir a chave Wi-Fi e digitalizar o QR Code do produto ou introduzir o código manualmente.



Ligue o dispositivo e va a rede, depois a WLAN (introduza as suas informações de início de sessão), clique em Código QR (digitalize o Código QR que aparece no monitor)

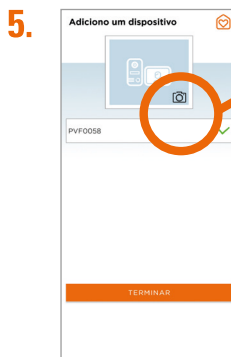

Nominare il videocitofono e la stanza in cui è installato il prodotto.



Adicionar uma fotografia de perfil a partir da câmara fotográfica, da galeria ou seleccionar uma imagem predefinida (imagem do produto)

F- DEFINIÇÕES

Configuração da aplicação

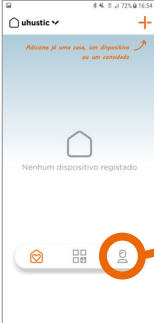
- 

1. Pressionar para aceder às configurações da aplicação.
- 

2. Ver o meu perfil: Para modificar as informações pessoais.

Para adicionar uma casa

- 

1. Adicionar uma casa.
- 

2. Criar uma nova casa.
- 

3. Introduzir os campos e pressionar «TERMINAR».

Para eliminar uma casa

- 

1. Clicar em 
- 

2. Pressionar para eliminar uma casa.
- 

3. Confirmar a eliminação.

Para modificar uma casa

- 

1. Pressionar 
- 

2. Modificar a morada.
- 

3.

Configurações de notificações

- 

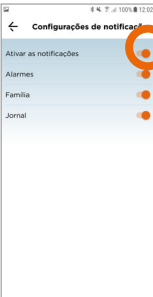
1. Pressionar  para aceder às definições de notificações.
- 

2. Pressionar «Ativar as notificações» para ativar todas as notificações. Caso contrário, pressionar as notificações desejadas.

Utilização da aplicação

- 

1. Prima para falar.
- 

2. Capturar a fotografia no seu telemóvel.
- 

3. Ativar o ecrã total (alternar o telemóvel).
- 

4. Gestão de postos de porta
- 

5. Acionar o portal
- 

6. Acionar a greve

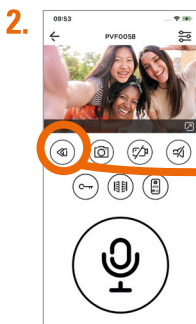

2. Repetição: ver o que aconteceu.

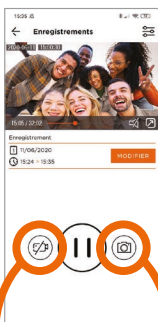

Gravar um vídeo

Guardar uma fotografia

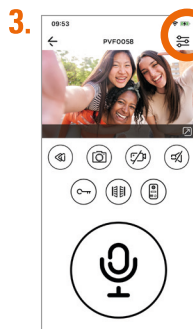

3. pour Prima para alterar as definições do videofone.



Por defeito, o videofone aparece na lista de favoritos assim que abre a aplicação.

Prima o botão para adicionar/remover o videofone dos seus favoritos.

Cenário

Un scénario est une action qui suit un/des événement(s) déclencheurs.

- 1 Sélectionnez le/les événements déclencheurs. Si vous avez plusieurs déclencheurs, vous avez le choix entre les combiner ensemble (ET) ou les dissocier pour réaliser l'action (OU).
- 2 Définissez le/les actions à réaliser.
- 3 Enregistrez votre scénario.

Ensuite, l'application lancera le/les action(s) du scénario, lorsqu'il aura repéré un déclencheur

SUIVANT

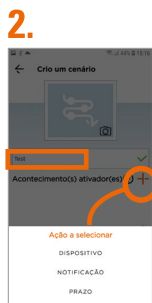

1. Para seleccionar um ou mais eventos acionadores (dispositivo, data/hora ou local) pressionar +



2. Para seleccionar uma ou mais acções (dispositivo, notificação ou prazo) pressionar +



3. Por defeito, o cenário aparece na lista dos favoritos.



● O cenário está ativado

▶ Ativar as «ações» do cenário sem esperar pelos «eventos acionadores»

Adicionar convidados



⚠ Através da aplicação iSCS Sentinel, um convidado pode ativar / desativar os dispositivos, mas não pode configurá-los.

Reset

Para apagar completamente o dispositivo, terá de o apagar na aplicação.

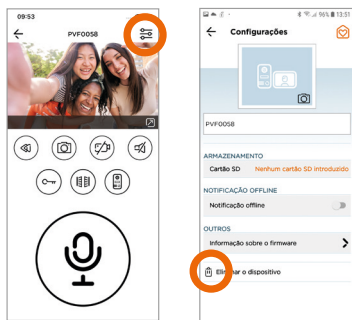

G- CARACTERÍSTICAS TÉCNICAS

Monitor

Alimentação	24V DC 1A 24W
Ecrã	Ecrã tátil de 10" TFT LCD
Dimensões	255 x 180 x 28,5 mm
Resolução do LCD	1024 x 600 px
Possibilidade de memória externa num cartão micro SD (fotografias ou vídeos)	4 GB - 128 GB classe 4 (não fornecido) o cartão micro SD deve ser formatado antes da utilização
Frequência de funcionamento	2412 MHz - 2472 MHz
Potência máxima de transmissão	< 100mW
Wi-Fi	802 11b/g/n

Estação de porta

Alimentação	23V DC 0,2A
Dimensões	68 x 159 x 31 mm
Resolução HD	1080 x 720 px
Ângulo de visão	110°
Visão noturna	LED de infravermelhos
Temperatura de funcionamento	-20°C / + 50°C
Classe de proteção	IP65

Adaptador elétrico

Número do modelo	MX24W1-2401000V
Tensão de entrada	100-240V AC
Frequência AC de entrada	50/60Hz
Tensão de saída	24V DC
Corrente de saída	1A
Potência de saída	24W
Eficiência média no modo ativo	88,29%
Eficiência a baixa carga (10%)	84,51%
Consumo de energia sem carga	0,084W

Modo de espera

Consumo de energia em modo de espera	3,8W
Tempo até entrar em modo de espera	15 minutos

H - ASSISTÊNCIA TÉCNICA

Chat em direto



Tem uma dúvida?

Para uma resposta personalizada, utilize o nosso chat em direto através da página www.scs-sentinel.com

I- GARANTIA



Guarde cuidadosamente o código de barras e o comprovativo de compra, eles serão pedidos para acionar a garantia.

É obrigatório guardar um comprovativo de compra durante todo o período da garantia.

J- AVISOS

- Manter uma distância mínima (10 cm) à volta do aparelho para garantir uma ventilação adequada.
- Não obstruir as aberturas de ventilação com objectos como jornais, toalhas de mesa, cortinas, etc.
- Não colocar chamas livres, tais como velas acesas, perto do aparelho.
- O funcionamento normal do produto pode ser afetado por fortes interferências electromagnéticas.
- Este equipamento destina-se apenas a utilização doméstica.
- O monitor e o respetivo adaptador não devem ser expostos a pingos ou salpicos de água. Os objectos cheios de líquidos, como vasos, não devem ser colocados em cima deste equipamento.
- A ficha de alimentação deve estar facilmente acessível. É utilizada como dispositivo de desconexão.
- O monitor e o adaptador devem ser utilizados em espaços interiores.
- Efetuar todas as ligações entre os componentes antes de ligar o kit.
- Ligue o seu aparelho apenas com o adaptador fornecido.
- Como os componentes são constituídos por componentes electrónicos, devem ser manuseados com cuidado.
- Não bloquear o microfone do posto de controlo e do monitor.
- Ao instalar o seu produto, não deixe a embalagem ao alcance de crianças ou animais domésticos. Estes representam uma fonte potencial de perigo.
- Este produto não é um brinquedo. Não foi concebido para ser utilizado por crianças.

 Antes de qualquer manutenção, desligar os seus dispositivos. Não limpar o produto com solventes, substâncias abrasivas ou corrosivas. Utilizar um pano macio. Não vaporizar nada sobre o produto.

 Fazer uma boa manutenção do seu produto e verificar frequentemente a instalação para detetar qualquer sinal de desgaste. Não utilizar o aparelho se for necessário reparar ou ajustar. Chame pessoal qualificado.

 Não deitar fora os dispositivos nem as pilhas junto com o lixo comum. As substâncias perigosas que eles possam conter podem ser prejudiciais à saúde e ao ambiente. Utilize os serviços de recolha seletiva disponíveis na sua localidade ou distribuidor.



Explicação dos símbolos :

== Corrente contínua ~ Corrente alternada □ Modelo de classe II

 O monitor e o adaptador destinam-se apenas a utilização em interiores.

IP 65 : A unidade exterior está protegida contra poeiras e jactos de água vindos de todas as direcções.

K- DECLARAÇÃO DE CONFORMIDADE

Por este meio, a SCS Sentinel declara que este produto está conforme com as exigências fundamentais e outras disposições pertinentes da diretiva 2014/53/UE. A declaração de conformidade pode ser consultada em: www.scs-sentinel.com/downloads.

Toutes les infos sur :
www.scs-sentinel.com



SCS sentinel

110, rue Pierre-Gilles de Gennes
49300 Cholet - France

