

LED

2x7W
230/240V - 50Hz
Incluida - Incluída
Included



Uso interior
Uso interior
Indoor use



Requiere instalación
Necessita instalação
Requires installation

Cuando sea el momento de desechar el producto, por favor considere el impacto medioambiental y llévalo a un punto adecuado para reciclar. Los plásticos y metales utilizados en la construcción de este aparato pueden ser separados para permitir su reciclaje. Pregunte a su centro más cercano para más detalles. Todos nosotros podemos participar en la protección del medio ambiente.

Quando for necessário eliminar o produto, por favor considere o impacto ambiental e leve-o a um ecoponto adequado para reciclar. Os plásticos e metais utilizados na construção deste equipamento podem ser separados para permitir a sua reciclagem. Pergunte no centro de reciclagem que lhe está mais próximo, para mais detalhes. Todos nós podemos participar na protecção do meio ambiente.

When the time comes to eliminate this product, please consider the environmental impact and take it to recognised recycling facility instead of disposing it with general household waste. Take the equipment to a waste disposal site. Plastic and metal parts that are used in the construction of this appliance can be separated into pure grade which allow recycling. Ask to your service centre for details. Everyone of us can participate on the environmental protection.

El Corte Inglés S.A.

Hermosilla 112 - 28009 Madrid
Espana / Espanha / Spain. NIF: A-28017895
Fabricado en / na China / Made in China
elcorteingles.es



APLIQUE DANA

REF.: 460 02015
460 02023

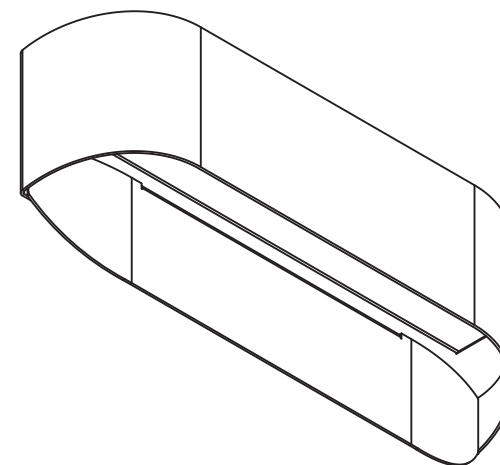

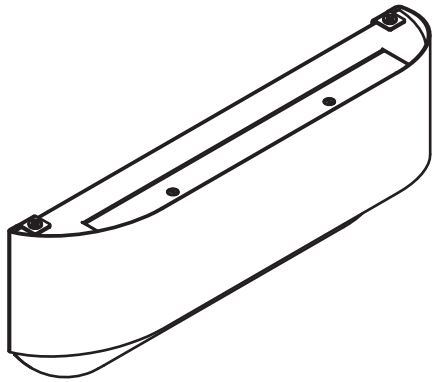

x1



x2



x2



x2



x1

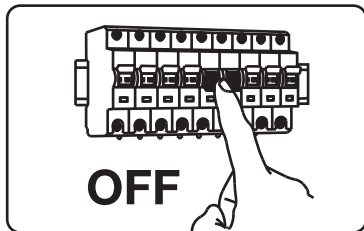
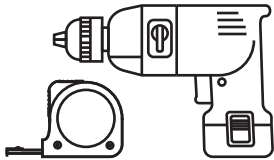

OFF

