

AIR CONDITIONER

**Cassette type**

# DESIGN & TECHNICAL MANUAL

---



INDOOR

AUXG09KVLA  
AUXG12KVLA  
AUXG14KVLA  
AUXG18KVLA  
AUXG22KVLA



OUTDOOR

AOHG09KBTB  
AOHG12KBTB  
AOHG14KBTB



AOHG18KBTB  
AOHG22KBTB

**FUJITSU GENERAL LIMITED**

**Notices:**

- Product specifications and design are subject to change without notice for future improvement.
- For further details, please check with our authorized dealer.

**Trademarks**

FGLair™ is trademark of Fujitsu General Limited in the United States, other countries or both.

Google Play™ is trademark of Google Inc.

App Store® is a service mark of Apple Inc., registered in the U.S. and other countries.

# CONTENTS

---

<b>Part 1. INDOOR UNIT</b> .....	<b>1</b>
<b>1. Specifications</b> .....	<b>2</b>
<b>2. Dimensions</b> .....	<b>6</b>
2-1. Models: AUXG09KVLA, AUXG12KVLA, AUXG14KVLA, AUXG18KVLA, and AUXG22KVLA .....	6
2-2. Installation space requirement .....	7
<b>3. Wiring diagram</b> .....	<b>8</b>
3-1. Models: AUXG09KVLA, AUXG12KVLA, AUXG14KVLA, AUXG18KVLA, and AUXG22KVLA .....	8
<b>4. Capacity table</b> .....	<b>9</b>
4-1. Cooling capacity.....	9
4-2. Heating capacity .....	11
<b>5. Fan performance</b> .....	<b>13</b>
5-1. Air velocity distributions.....	13
5-2. Airflow .....	23
<b>6. Operation noise (sound pressure)</b> .....	<b>28</b>
6-1. Noise level curve.....	28
6-2. Sound level check point .....	31
<b>7. Safety devices</b> .....	<b>32</b>
<b>8. External input and output</b> .....	<b>33</b>
8-1. External input.....	33
8-2. External output.....	34
8-3. Combination of external input and output.....	35
8-4. Details of function .....	36
<b>9. Function settings</b> .....	<b>39</b>
9-1. Function settings on indoor unit .....	39
9-2. Function settings by using remote controller .....	41
<b>10. Accessories</b> .....	<b>47</b>
10-1. Models: AUXG09KVLA, AUXG12KVLA, AUXG14KVLA, AUXG18KVLA, and AUXG22KVLA .....	47
<b>11. Optional parts</b> .....	<b>48</b>
11-1. Controllers .....	48
11-2. Cassette grille .....	49
11-3. Others .....	50

## CONTENTS (continued)

---

<b>Part 2. OUTDOOR UNIT</b> .....	<b>51</b>
<b>1. Specifications</b> .....	<b>52</b>
<b>2. Dimensions</b> .....	<b>54</b>
2-1. Models: AOHG09KBTB, AOHG12KBTB, and AOHG14KBTB.....	54
2-2. Models: AOHG18KBTB and AOHG22KBTB.....	55
<b>3. Installation space</b> .....	<b>56</b>
3-1. Models: AOHG09KBTB, AOHG12KBTB, AOHG14KBTB, AOHG18KBTB, and AOHG22KBTB.....	56
<b>4. Refrigerant circuit</b> .....	<b>59</b>
4-1. Models: AOHG09KBTB, AOHG12KBTB, and AOHG14KBTB.....	59
4-2. Model: AOHG18KBTB.....	60
4-3. Model: AOHG22KBTB.....	61
<b>5. Wiring diagrams</b> .....	<b>62</b>
5-1. Model: AOHG09KBTB.....	62
5-2. Models: AOHG12KBTB, AOHG14KBTB, and AOHG18KBTB.....	63
5-3. Model: AOHG22KBTB.....	64
<b>6. Capacity compensation rate for pipe length and height difference</b> .....	<b>65</b>
6-1. Model: AOHG09KBTB.....	65
6-2. Model: AOHG12KBTB.....	66
6-3. Model: AOHG14KBTB.....	67
6-4. Model: AOHG18KBTB.....	68
6-5. Model: AOHG22KBTB.....	69
<b>7. Additional charge calculation</b> .....	<b>70</b>
7-1. Model: AOHG09KBTB.....	70
7-2. Models: AOHG12KBTB and AOHG14KBTB.....	70
7-3. Model: AOHG18KBTB.....	70
7-4. Model: AOHG22KBTB.....	70
<b>8. Airflow</b> .....	<b>71</b>
8-1. Model: AOHG09KBTB.....	71
8-2. Model: AOHG12KBTB.....	71
8-3. Model: AOHG14KBTB.....	71
8-4. Model: AOHG18KBTB.....	72
8-5. Model: AOHG22KBTB.....	72
<b>9. Operation noise (sound pressure)</b> .....	<b>73</b>
9-1. Noise level curve.....	73
9-2. Sound level check point.....	75
<b>10. Electrical characteristics</b> .....	<b>76</b>
<b>11. Safety devices</b> .....	<b>77</b>
<b>12. Accessories</b> .....	<b>78</b>

## **CONTENTS (continued)**

12-1.Models: AOHG09KBTB, AOHG12KBTB, AOHG14KBTB, AOHG18KBTB, and AOHG22KBTB .....	78
--	----



# Part 1. INDOOR UNIT

---

## CASSETTE TYPE:

AUXG09KVLA

AUXG12KVLA

AUXG14KVLA

AUXG18KVLA

AUXG22KVLA

# 1. Specifications

Type				Cassette						
				Inverter heat pump						
Model name				AUXG09KVLA	AUXG12KVLA	AUXG14KVLA				
Power supply				230 V ~ 50 Hz						
Power supply intake				Outdoor unit						
Available voltage range				198—264 V						
Capacity	Cooling	Rated	kW	2.50	3.50	4.30				
			Btu/h	8,500	11,900	14,700				
		Min.—Max.	kW	0.90—3.20	0.90—4.40	0.90—5.40				
	Heating	Rated	Btu/h	3,100—10,900	3,100—15,000	3,100—18,400				
			kW	3.20	4.10	5.00				
		Min.—Max.	Btu/h	10,900	13,400	17,000				
Input power	Cooling	Rated	kW	0.55	0.93	1.28				
			Max.	1.82	2.24	2.35				
		Rated	0.79	1.08	1.32					
	Heating	Rated	kW	1.82	2.24	2.35				
			Max.	2.9	4.1	5.6				
		Rated	4.0	4.8	5.8					
Power factor				Cooling	82.5	98.6	99.4			
				Heating	85.9	97.8	99.0			
EER				Cooling	4.57	3.76	3.36			
COP				Heating	4.05	3.80	3.79			
Moisture removal				L/h (pints/h)	0.6 (1.1)	1.2 (2.1)	1.5 (2.6)			
Maximum operating current *1				Cooling	7.9	9.7	10.2			
				Heating	7.9	9.7	10.2			
Fan	Airflow rate	Cooling	HIGH	540	600	680				
			MED	490	530	580				
			LOW	440	470	490				
			QUIET	390	410	410				
		Heating	HIGH	540	600	800				
			MED	490	530	680				
			LOW	440	470	580				
			QUIET	390	410	450				
	Type × Q'ty				Turbo × 1					
	Motor output				W					
				54						
Sound pressure level *2				Cooling	HIGH	33	37	38		
					MED	31	34	34		
					LOW	29	30	30		
					QUIET	27	27	27		
				Heating	HIGH	34	37	43		
					MED	32	34	38		
					LOW	29	31	34		
					QUIET	27	29	30		
Heat exchanger type				Dimensions (H × W × D)	210 × 1,310 × 13.3 210 × 1,250 × 13.3					
				Fin pitch	1.2					
				Rows × Stages	2 × 10					
				Pipe type	Copper tube					
				Fin type	Aluminum					
Dimensions (H × W × D)				Net	245 × 570 × 570					
				Gross	265 × 730 × 625					
Weight				Net	15					
				Gross	19					
Connection pipe				Size	Liquid	Ø 6.35 (Ø1/4)				
					Gas	Ø9.52 (Ø3/8)				
				Method	Flare					
Operation range				Cooling	°C	18 to 32				
					%RH	80 or less				
				Heating	°C					
					16 to 30					
Cassette grille (Grid type: Option)				Material			Polystyrene			
				Color			White			
							Approximate color of Munsell 9PB 9.1/0.2			
				Dimensions (H × W × D)	Net	Gross	mm	49 × 620 × 620		
								120 × 765 × 755		
Weight	Net	Gross	kg	2.3						
				4.5						
Remote control (Option)				Wired remote controller, Wireless remote controller, Mobile app*3 (FGLair™)						
Drain hose				Material			PVC			
				Size			mm			
				VP25 [Ø25(I.D.), Ø32(O.D.)]						

## NOTES:

- Specifications are based on the following conditions:
  - Cooling: Indoor temperature of 27 °CDB/19 °CWB, and outdoor temperature of 35 °CDB/24 °CWB.
  - Heating: Indoor temperature of 20 °CDB/15 °CWB, and outdoor temperature of 7 °CDB/6 °CWB.
  - Pipe length: 5 m, Height difference: 0 m. (Between outdoor unit and indoor unit.)
- Protective function might work when using it outside the operation range.
- \*1: Maximum operating current is the total current of the indoor unit and the outdoor unit.
- \*2: Sound pressure level:
  - Measured values in manufacturer's anechoic chamber.
  - Because of the surrounding sound environment, the sound levels measured in actual installation conditions might be higher than the specified values here.
- \*3: Available on Google Play™ store or on App Store®. Optional WLAN adapter is also required. For details, refer to the setting manual.
- This data is based on EN 14511 standard.

Specifications for ErP Lot10						
Model name		AUXG09KVLA		AUXG12KVLA	AUXG14KVLA	
Energy efficiency class	Cooling	A++				
	Heating (Average)	A*				
Pdesign	Cooling	kW	2.5 (35°C)	3.5 (35°C)	4.3 (35°C)	
	Heating (Average)		2.6 (-10°C)	3.4 (-10°C)	3.8 (-10°C)	
SEER	Cooling	kWh/kWh	6.70	6.60	6.50	
SCOP	Heating (Average)		4.40	4.30	4.40	
Annual energy consumption	QCE	kWh/a	131	186	231	
	QHE (Average)		826	1,106	1,208	
Sound power level	Cooling	HIGH	dB (A)	46	49	50
	Heating			47	49	55

Type				Cassette		
				Inverter heat pump		
Model name				AUXG18KVLA	AUXG22KVLA	
Power supply				230 V ~ 50 Hz		
Power supply intake				Outdoor unit		
Available voltage range				198—264 V		
Capacity	Cooling	Rated	kW	5.20	6.00	
			Btu/h	17,700	20,500	
		Min.—Max.	kW	0.90—5.90	0.90—6.70	
	Heating	Rated	Btu/h	3,100—20,100	3,100—22,900	
			kW	6.00	7.00	
			Btu/h	20,500	23,900	
Min.—Max.		kW	0.90—7.50	0.90—8.00		
		Btu/h	3,100—25,600	3,100—27,300		
Input power	Cooling	Rated	kW	1.60	1.82	
		Max.		2.79	2.90	
	Heating	Rated		1.66	1.87	
		Max.		2.79	2.90	
Current	Cooling	Rated	A	7.0	8.0	
	Heating		7.3	8.2		
Power factor	Cooling			99.4	98.9	
	Heating			98.9	99.2	
EER	Cooling			3.25	3.30	
COP	Heating			3.61	3.74	
Moisture removal			L/h (pints/h)	2.2 (3.9)	2.6 (4.6)	
Maximum operating current *1		Cooling	A	12.1	12.6	
		Heating		12.1	12.6	
Fan	Airflow rate	Cooling	HIGH	m <sup>3</sup> /h	680	830
			MED		580	740
			LOW		490	600
			QUIET		410	450
		Heating	HIGH		800	860
			MED		680	760
			LOW		580	700
			QUIET		450	530
	Type × Q'ty				Turbo × 1	
	Motor output		W		54	
Sound pressure level *2	Cooling	HIGH	dB (A)	38	44	
		MED		34	42	
		LOW		30	36	
		QUIET		26	30	
	Heating	HIGH		43	45	
		MED		38	43	
		LOW		34	40	
		QUIET		30	33	
Heat exchanger type	Dimensions (H × W × D)		mm	210 × 1,310 × 13.3	210 × 1,360 × 13.3	
				210 × 1,250 × 13.3	210 × 1,295 × 13.3	
	Fin pitch			1.2	1.45	
	Rows × Stages			2 × 10	3 × 10	
	Pipe type				Copper tube	
Fin type				Aluminum		
Dimensions (H × W × D)	Net		mm	245 × 570 × 570		
	Gross			265 × 730 × 625		
Weight	Net		kg	15	16	
	Gross			19	20	
Connection pipe	Size	Liquid	mm (in)	Ø 6.35 (Ø1/4)		
		Gas		Ø12.70 (Ø1/2)		
	Method				Flare	
Operation range	Cooling			°C	18 to 32	
				%RH	80 or less	
	Heating			°C	16 to 30	
Cassette grille (Grid type: Option)	Material				Polystyrene	
	Color				White	
					Approximate color of Munsell 9PB 9.1/0.2	
	Dimensions (H × W × D)	Net	mm	49 × 620 × 620		
		Gross		120 × 765 × 755		
Weight	Net	kg	2.3			
	Gross		4.5			
Remote control (Option)				Wired remote controller, Wireless remote controller, Mobile app*3 (FGLair™)		
Drain hose	Material				PVC	
	Size		mm		VP25 [Ø25(I.D.),Ø32(O.D.)]	

**NOTES:**

- Specifications are based on the following conditions:
  - Cooling: Indoor temperature of 27 °CDB/19 °CWB, and outdoor temperature of 35 °CDB/24 °CWB.
  - Heating: Indoor temperature of 20 °CDB/15 °CWB, and outdoor temperature of 7 °CDB/6 °CWB.
  - Pipe length: 5 m, Height difference: 0 m. (Between outdoor unit and indoor unit.)
  -
- Protective function might work when using it outside the operation range.
- \*1: Maximum operating current is the total current of the indoor unit and the outdoor unit.
- \*2: Sound pressure level:
  - Measured values in manufacturer's anechoic chamber.
  - Because of the surrounding sound environment, the sound levels measured in actual installation conditions might be higher than the specified values here.
- \*3: Available on Google Play™ store or on App Store®. Optional WLAN adapter is also required. For details, refer to the setting manual.
- This data is based on EN 14511 standard.

Specifications for ErP Lot10				
Model name		AUXG18KVLA		AUXG22KVLA
Energy efficiency class	Cooling	A <sup>++</sup>		
	Heating (Average)	A <sup>+</sup>		
Pdesign	Cooling	kW	5.2 (35°C)	6.0 (35°C)
	Heating (Average)		4.4 (-10°C)	4.8 (-10°C)
SEER	Cooling	kWh/kWh	6.60	6.60
SCOP	Heating (Average)		4.20	4.30
Annual energy consumption	QCE	kWh/a	275	318
	QHE (Average)		1,466	1,562
Sound power level	Cooling	HIGH	dB (A)	50
	Heating			55
				56
				57



## 2-2. Installation space requirement

Unit: mm

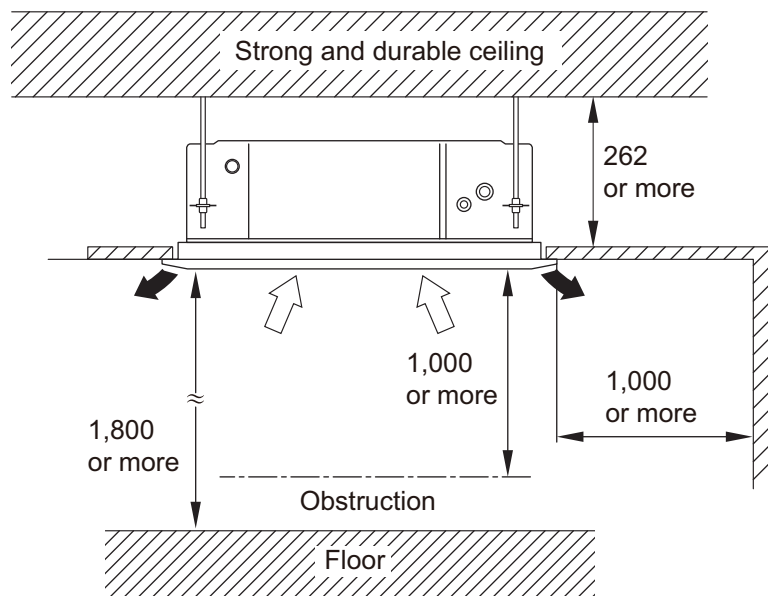

Maximum height from floor to ceiling (Unit: mm)	
Standard	2,700
High ceiling	3,000

### 3-way direction setting:

Unit: mm

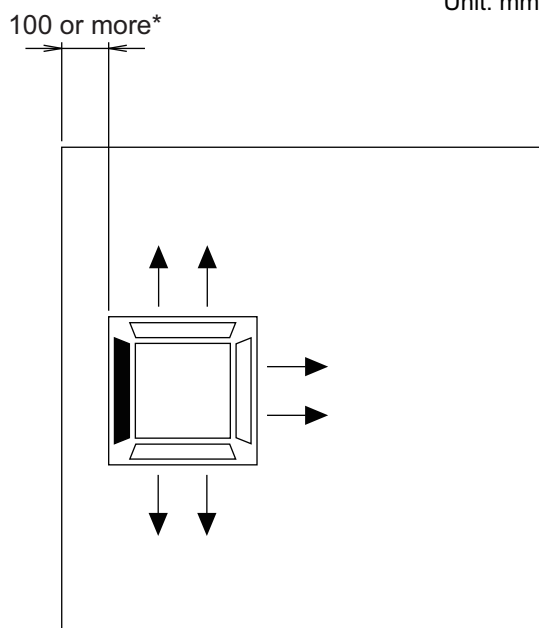

### NOTES:

- To set "3-direction", optional Air outlet shutter plate (UTR-YDZB) must be installed, and the "outlet-direction" need to be switched to "3-way" by remote controller.  
\*When installing the indoor unit, be careful about the maintenance space.
- In 3-way outlet mode, changing of ceiling height setting by function setting 20 is prohibited.  
(Ceiling height setting [function setting 20] is allowed to be changed only in 4-way outlet mode.)

### 3. Wiring diagram

#### 3-1. Models: AUXG09KVLA, AUXG12KVLA, AUXG14KVLA, AUXG18KVLA, and AUXG22KVLA

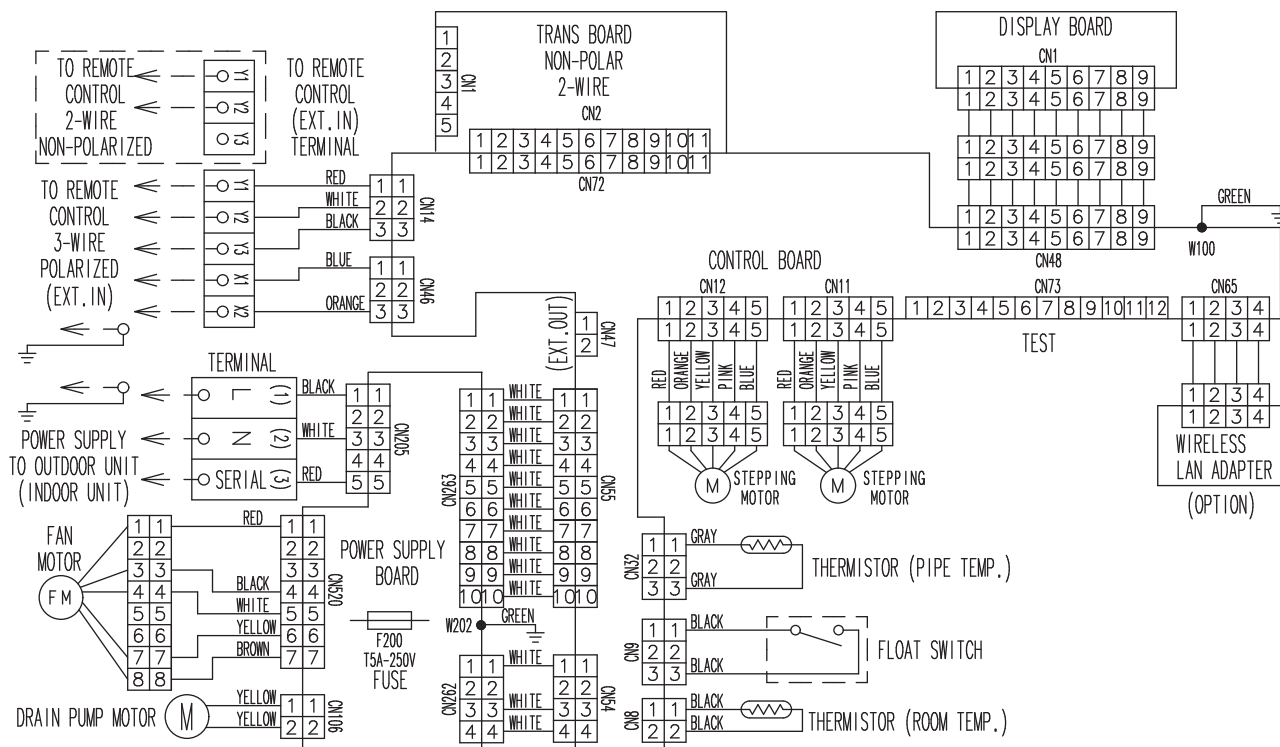

## 4. Capacity table

Capacity tables show each of following values calculated based on the outdoor temperature and the indoor temperature, under given Airflow Rate (AFR):

**For cooling capacity:** Total Capacity (TC), Sensible Heat Capacity (SHC), and Input Power (IP)

**For heating capacity:** Total Capacity (TC) and Input Power (IP)

### 4-1. Cooling capacity

#### ■ Model: AUXG09KVL

AFR		m <sup>3</sup> /h																		540		
Outdoor temperature	Indoor temperature																					
	°CDB	18			21			23			25			27			29			32		
	°CWB	12			15			16			18			19			21			23		
	°CDB	TC	SHC	IP	TC	SHC	IP	TC	SHC	IP	TC	SHC	IP	TC	SHC	IP	TC	SHC	IP	TC	SHC	IP
		kW			kW			kW			kW			kW			kW			kW		
-15	2.03	1.62	0.49	2.26	1.63	0.50	2.34	1.77	0.50	2.49	1.78	0.51	2.57	1.92	0.51	2.72	1.91	0.52	2.88	2.04	0.52	
-10	1.89	1.57	0.56	2.10	1.58	0.57	2.17	1.72	0.57	2.32	1.72	0.58	2.39	1.86	0.58	2.53	1.85	0.59	2.68	1.97	0.59	
0	2.09	1.66	0.34	2.33	1.67	0.34	2.41	1.82	0.34	2.57	1.82	0.35	2.65	1.97	0.35	2.81	1.96	0.35	2.97	2.09	0.36	
5	2.04	1.65	0.39	2.27	1.66	0.39	2.35	1.80	0.39	2.50	1.81	0.40	2.58	1.95	0.40	2.73	1.94	0.40	2.89	2.07	0.41	
10	2.14	1.69	0.33	2.38	1.70	0.33	2.47	1.85	0.33	2.63	1.85	0.34	2.71	2.00	0.34	2.87	1.99	0.34	3.04	2.12	0.35	
15	2.08	1.66	0.38	2.31	1.67	0.38	2.39	1.82	0.38	2.55	1.82	0.39	2.63	1.97	0.39	2.79	1.96	0.39	2.95	2.09	0.40	
20	2.22	1.74	0.40	2.47	1.75	0.40	2.56	1.90	0.40	2.73	1.91	0.41	2.81	2.06	0.41	2.98	2.05	0.41	3.15	2.19	0.42	
25	2.13	1.75	0.44	2.38	1.76	0.45	2.46	1.91	0.45	2.62	1.92	0.46	2.70	2.07	0.46	2.86	2.06	0.46	3.02	2.20	0.47	
30	2.05	1.76	0.48	2.29	1.77	0.49	2.37	1.92	0.49	2.52	1.93	0.50	2.60	2.08	0.50	2.76	2.07	0.51	2.91	2.21	0.51	
35	1.98	1.76	0.53	2.20	1.77	0.54	2.28	1.93	0.54	2.43	1.94	0.55	2.50	2.09	0.55	2.65	2.08	0.56	2.80	2.22	0.56	
40	1.90	1.76	0.61	2.11	1.77	0.62	2.18	1.93	0.62	2.33	1.94	0.63	2.40	2.09	0.63	2.54	2.08	0.64	2.69	2.22	0.64	
46	1.81	1.76	0.69	2.02	1.77	0.71	2.08	1.92	0.71	2.22	1.93	0.72	2.29	2.08	0.72	2.43	2.07	0.73	2.56	2.21	0.73	

#### ■ Model: AUXG12KVL

AFR		m <sup>3</sup> /h																		600		
Outdoor temperature	Indoor temperature																					
	°CDB	18			21			23			25			27			29			32		
	°CWB	12			15			16			18			19			21			23		
	°CDB	TC	SHC	IP	TC	SHC	IP	TC	SHC	IP	TC	SHC	IP	TC	SHC	IP	TC	SHC	IP	TC	SHC	IP
		kW			kW			kW			kW			kW			kW			kW		
-15	2.92	2.46	0.70	3.25	2.48	0.72	3.36	2.70	0.72	3.58	2.70	0.73	3.69	2.92	0.73	3.91	2.91	0.74	4.13	3.10	0.74	
-10	3.11	2.55	0.59	3.47	2.56	0.60	3.59	2.79	0.60	3.82	2.80	0.61	3.94	3.02	0.61	4.18	3.01	0.62	4.41	3.20	0.62	
0	3.45	2.70	0.40	3.85	2.72	0.40	3.98	2.95	0.40	4.24	2.96	0.41	4.37	3.20	0.41	4.63	3.19	0.41	4.89	3.40	0.42	
5	3.31	2.63	0.46	3.69	2.65	0.47	3.81	2.88	0.47	4.06	2.89	0.48	4.19	3.12	0.48	4.44	3.11	0.48	4.69	3.31	0.49	
10	3.39	2.65	0.47	3.78	2.67	0.48	3.90	2.90	0.48	4.16	2.91	0.49	4.29	3.14	0.49	4.55	3.13	0.49	4.80	3.33	0.50	
15	3.29	2.61	0.56	3.67	2.62	0.57	3.79	2.85	0.57	4.04	2.86	0.58	4.17	3.09	0.58	4.42	3.08	0.59	4.67	3.28	0.59	
20	3.29	2.62	0.62	3.67	2.64	0.63	3.79	2.87	0.63	4.04	2.88	0.64	4.17	3.11	0.64	4.42	3.10	0.65	4.67	3.30	0.65	
25	3.11	2.51	0.71	3.47	2.52	0.73	3.59	2.74	0.73	3.82	2.75	0.74	3.94	2.97	0.74	4.18	2.96	0.75	4.41	3.15	0.75	
30	2.94	2.38	0.81	3.27	2.39	0.82	3.39	2.60	0.83	3.61	2.61	0.84	3.72	2.82	0.84	3.94	2.81	0.85	4.17	2.99	0.86	
35	2.77	2.26	0.90	3.08	2.28	0.91	3.19	2.47	0.92	3.40	2.48	0.93	3.50	2.68	0.93	3.71	2.67	0.94	3.92	2.84	0.95	
40	2.68	2.23	0.99	2.98	2.24	1.01	3.08	2.44	1.01	3.29	2.44	1.02	3.39	2.64	1.03	3.59	2.63	1.04	3.80	2.80	1.05	
46	2.36	2.19	0.98	2.63	2.21	1.00	2.72	2.40	1.00	2.90	2.41	1.01	2.99	2.60	1.02	3.17	2.59	1.03	3.35	2.76	1.04	

#### ■ Model: AUXG14KVL

AFR		m <sup>3</sup> /h																		680		
Outdoor temperature	Indoor temperature																					
	°CDB	18			21			23			25			27			29			32		
	°CWB	12			15			16			18			19			21			23		
	°CDB	TC	SHC	IP	TC	SHC	IP	TC	SHC	IP	TC	SHC	IP	TC	SHC	IP	TC	SHC	IP	TC	SHC	IP
		kW			kW			kW			kW			kW			kW			kW		
-15	3.32	2.78	0.98	3.70	2.79	1.00	3.82	3.04	1.00	4.07	3.05	1.01	4.20	3.29	1.02	4.45	3.28	1.03	4.70	3.49	1.04	
-10	3.60	2.89	0.64	4.01	2.91	0.65	4.15	3.17	0.65	4.42	3.18	0.66	4.56	3.43	0.66	4.83	3.42	0.67	5.11	3.64	0.67	
0	3.74	2.96	0.45	4.17	2.98	0.46	4.31	3.24	0.46	4.60	3.25	0.47	4.74	3.51	0.47	5.02	3.50	0.47	5.31	3.72	0.48	
5	3.56	2.87	0.55	3.97	2.89	0.56	4.10	3.14	0.56	4.37	3.15	0.57	4.51	3.40	0.57	4.78	3.39	0.58	5.05	3.61	0.58	
10	3.61	2.84	0.55	4.02	2.85	0.56	4.16	3.10	0.56	4.43	3.11	0.57	4.57	3.36	0.57	4.84	3.35	0.58	5.12	3.56	0.58	
15	3.55	2.84	0.66	3.95	2.86	0.67	4.09	3.11	0.67	4.36	3.12	0.68	4.49	3.37	0.68	4.76	3.36	0.69	5.03	3.58	0.69	
20	3.94	3.06	0.88	4.39	3.07	0.89	4.54	3.34	0.90	4.84	3.35	0.91	4.99	3.62	0.91	5.29	3.61	0.92	5.59	3.84	0.93	
25	3.76	2.96	1.00	4.19	2.98	1.02	4.33	3.24	1.02	4.62	3.25	1.03	4.76	3.51	1.04	5.05	3.50	1.05	5.33	3.72	1.06	
30	3.58	2.86	1.12	3.99	2.88	1.14	4.12	3.13	1.14	4.39	3.14	1.15	4.53	3.39	1.16	4.80	3.38	1.17	5.07	3.60	1.18	
35	3.40	2.77	1.24	3.78	2.78	1.25	3.91	3.03	1.26	4.17	3.04	1.27	4.30	3.28	1.28	4.56	3.27	1.29	4.82	3.48	1.31	
40	3.25	2.70	1.33	3.63	2.72	1.35	3.75	2.95	1.36	4.00	2.96	1.37	4.12	3.20	1.38	4.37	3.19	1.39	4.61	3.40	1.41	
46	2.45	2.39	1.02	2.73	2.40	1.04	2.82	2.61	1.04	3.01	2.62	1.05	3.10	2.83	1.06	3.29	2.82	1.07	3.47	3.00	1.08	

# Model: AUXG18KVL A

AFR	m <sup>3</sup> /h	680
-----	-------------------	-----

		Indoor temperature																				
		18			21			23			25			27			29			32		
		°CWB			15			16			18			19			21			23		
Outdoor temperature	°CDB	TC	SHC	IP	TC	SHC	IP	TC	SHC	IP	TC	SHC	IP	TC	SHC	IP	TC	SHC	IP	TC	SHC	IP
		kW			kW			kW			kW			kW			kW			kW		
	-15	4.17	3.26	0.49	4.65	3.28	0.50	4.80	3.56	0.50	5.12	3.57	0.51	5.28	3.86	0.51	5.60	3.84	0.52	5.91	4.10	0.52
	-10	4.20	3.28	0.41	4.68	3.30	0.42	4.84	3.59	0.42	5.16	3.60	0.43	5.32	3.89	0.43	5.64	3.87	0.43	5.96	4.13	0.44
	0	3.99	3.21	0.65	4.44	3.23	0.66	4.60	3.51	0.66	4.90	3.52	0.67	5.05	3.80	0.67	5.35	3.78	0.68	5.66	4.03	0.68
	5	3.91	3.18	0.69	4.36	3.20	0.70	4.50	3.48	0.70	4.80	3.49	0.71	4.95	3.77	0.71	5.25	3.75	0.72	5.54	4.00	0.72
	10	4.05	3.24	0.47	4.51	3.26	0.48	4.67	3.54	0.48	4.98	3.56	0.49	5.13	3.84	0.49	5.44	3.82	0.49	5.75	4.07	0.50
	15	3.92	3.20	0.58	4.36	3.22	0.59	4.51	3.50	0.59	4.81	3.51	0.60	4.96	3.79	0.60	5.26	3.77	0.61	5.56	4.02	0.61
	20	4.83	3.53	1.11	5.39	3.55	1.13	5.57	3.86	1.13	5.94	3.87	1.14	6.12	4.18	1.15	6.49	4.16	1.16	6.85	4.43	1.17
	25	4.59	3.39	1.25	5.11	3.41	1.27	5.29	3.71	1.28	5.64	3.72	1.29	5.81	4.02	1.30	6.16	4.00	1.31	6.51	4.27	1.33
	30	4.35	3.26	1.41	4.84	3.28	1.43	5.01	3.56	1.44	5.34	3.57	1.45	5.50	3.86	1.46	5.83	3.84	1.47	6.16	4.10	1.49
	35	4.11	3.12	1.54	4.58	3.14	1.57	4.73	3.42	1.58	5.04	3.43	1.59	5.20	3.70	1.60	5.51	3.69	1.62	5.82	3.93	1.63
40	3.68	3.05	1.41	4.10	3.06	1.43	4.24	3.33	1.44	4.52	3.34	1.45	4.66	3.61	1.46	4.94	3.60	1.47	5.22	3.83	1.49	
46	2.58	2.58	1.05	2.87	2.63	1.07	2.97	2.86	1.07	3.16	2.87	1.08	3.26	3.10	1.09	3.46	3.09	1.10	3.65	3.29	1.11	

# Model: AUXG22KVL A

AFR	m <sup>3</sup> /h	830
-----	-------------------	-----

		Indoor temperature																				
		18			21			23			25			27			29			32		
		°CWB			15			16			18			19			21			23		
Outdoor temperature	°CDB	TC	SHC	IP	TC	SHC	IP	TC	SHC	IP	TC	SHC	IP	TC	SHC	IP	TC	SHC	IP	TC	SHC	IP
		kW			kW			kW			kW			kW			kW			kW		
	-15	4.99	3.61	0.58	5.56	3.63	0.59	5.75	3.95	0.59	6.13	3.96	0.60	6.32	4.28	0.60	6.70	4.26	0.61	7.08	4.54	0.61
	-10	5.03	3.62	0.49	5.61	3.64	0.50	5.80	3.96	0.50	6.18	3.97	0.51	6.37	4.29	0.51	6.75	4.27	0.52	7.13	4.55	0.52
	0	4.91	3.57	0.50	5.46	3.59	0.51	5.65	3.90	0.51	6.02	3.92	0.52	6.21	4.23	0.52	6.58	4.21	0.53	6.96	4.49	0.53
	5	4.77	3.52	0.64	5.32	3.54	0.65	5.50	3.85	0.65	5.86	3.86	0.66	6.04	4.17	0.66	6.40	4.15	0.67	6.76	4.42	0.67
	10	4.74	3.51	0.62	5.28	3.53	0.63	5.46	3.84	0.63	5.82	3.85	0.64	6.00	4.16	0.64	6.36	4.14	0.65	6.72	4.41	0.65
	15	4.59	3.45	0.75	5.11	3.47	0.76	5.29	3.78	0.77	5.64	3.79	0.78	5.81	4.09	0.78	6.16	4.07	0.79	6.51	4.34	0.80
	20	5.77	3.94	1.33	6.43	3.96	1.35	6.65	4.31	1.36	7.09	4.32	1.37	7.31	4.67	1.38	7.75	4.65	1.39	8.19	4.95	1.41
	25	5.43	3.81	1.48	6.05	3.84	1.50	6.25	4.17	1.51	6.66	4.19	1.52	6.87	4.52	1.53	7.28	4.50	1.55	7.69	4.80	1.56
	30	5.08	3.69	1.62	5.66	3.71	1.65	5.85	4.03	1.65	6.24	4.05	1.67	6.43	4.37	1.68	6.82	4.35	1.70	7.20	4.64	1.71
	35	4.74	3.56	1.76	5.28	3.58	1.78	5.46	3.90	1.79	5.82	3.91	1.81	6.00	4.22	1.82	6.36	4.20	1.84	6.72	4.48	1.86
40	4.50	3.45	1.90	5.01	3.47	1.93	5.18	3.78	1.94	5.52	3.79	1.96	5.69	4.09	1.97	6.03	4.07	1.99	6.37	4.34	2.01	
46	3.69	3.06	1.64	4.11	3.07	1.67	4.25	3.34	1.67	4.53	3.35	1.69	4.67	3.62	1.70	4.95	3.61	1.72	5.23	3.84	1.73	

## 4-2. Heating capacity

NOTE: Values mentioned in the table are calculated based on the maximum capacity.

### Model: AUXG09KVLVA

AFR		m <sup>3</sup> /h		540											
		Indoor temperature													
		°CDB	16		18		20		22		24				
Outdoor temperature	°CDB	°CWB	TC	IP	TC	IP	TC	IP	TC	IP	TC	IP			
			kW		kW		kW		kW		kW				
	-15	-16	3.35	1.26	3.27	1.28	3.19	1.31	3.11	1.34	3.03	1.36			
	-10	-11	3.71	1.31	3.62	1.33	3.53	1.36	3.44	1.39	3.35	1.41			
	-5	-7	4.06	1.35	3.97	1.38	3.87	1.41	3.77	1.44	3.68	1.47			
	0	-2	4.42	1.40	4.32	1.43	4.21	1.46	4.10	1.49	4.00	1.52			
	5	3	4.79	1.45	4.67	1.48	4.56	1.51	4.45	1.54	4.33	1.57			
	7	6	4.94	1.46	4.82	1.49	4.70	1.52	4.58	1.55	4.47	1.58			
	10	8	5.17	1.49	5.04	1.52	4.92	1.55	4.80	1.58	4.67	1.61			
	15	10	5.10	1.29	4.98	1.31	4.86	1.34	4.74	1.37	4.62	1.39			
20	15	5.16	1.16	5.03	1.19	4.91	1.21	4.79	1.23	4.66	1.25				
24	18	5.42	1.17	5.29	1.20	5.16	1.22	5.03	1.24	4.90	1.26				

### Model: AUXG12KVLVA

AFR		m <sup>3</sup> /h		600											
		Indoor temperature													
		°CDB	16		18		20		22		24				
Outdoor temperature	°CDB	°CWB	TC	IP	TC	IP	TC	IP	TC	IP	TC	IP			
			kW		kW		kW		kW		kW				
	-15	-16	3.87	1.55	3.78	1.58	3.69	1.61	3.60	1.64	3.51	1.67			
	-10	-11	4.35	1.62	4.24	1.66	4.14	1.69	4.04	1.72	3.93	1.76			
	-5	-7	4.83	1.69	4.72	1.72	4.60	1.76	4.49	1.80	4.37	1.83			
	0	-2	5.31	1.76	5.19	1.79	5.06	1.83	4.93	1.87	4.81	1.90			
	5	3	5.79	1.82	5.65	1.86	5.51	1.90	5.37	1.94	5.23	1.98			
	7	6	5.99	1.84	5.84	1.88	5.70	1.92	5.56	1.96	5.42	2.00			
	10	8	6.13	1.80	5.99	1.84	5.84	1.88	5.69	1.92	5.55	1.96			
	15	10	6.37	1.74	6.22	1.77	6.07	1.81	5.92	1.85	5.77	1.87			
20	15	6.15	1.43	6.01	1.46	5.86	1.49	5.71	1.52	5.57	1.54				
24	18	6.09	1.27	5.95	1.29	5.80	1.32	5.66	1.35	5.51	1.37				

### Model: AUXG14KVLVA

AFR		m <sup>3</sup> /h		800											
		Indoor temperature													
		°CDB	16		18		20		22		24				
Outdoor temperature	°CDB	°CWB	TC	IP	TC	IP	TC	IP	TC	IP	TC	IP			
			kW		kW		kW		kW		kW				
	-15	-16	4.54	1.81	4.43	1.85	4.32	1.89	4.21	1.93	4.10	1.97			
	-10	-11	5.05	1.86	4.93	1.90	4.81	1.94	4.69	1.98	4.57	2.02			
	-5	-7	5.58	1.91	5.44	1.95	5.31	1.99	5.18	2.03	5.04	2.07			
	0	-2	6.09	1.95	5.95	1.99	5.80	2.03	5.66	2.07	5.51	2.11			
	5	3	6.62	2.00	6.46	2.04	6.30	2.08	6.14	2.12	5.99	2.16			
	7	6	6.83	2.01	6.66	2.05	6.50	2.09	6.34	2.13	6.18	2.17			
	10	8	6.96	1.94	6.80	1.98	6.63	2.02	6.46	2.06	6.30	2.10			
	15	10	7.21	1.83	7.04	1.87	6.87	1.91	6.70	1.95	6.53	1.98			
20	15	7.09	1.56	6.92	1.60	6.75	1.63	6.58	1.66	6.41	1.69				
24	18	7.47	1.56	7.29	1.60	7.11	1.63	6.93	1.66	6.75	1.69				

### Model: AUXG18KVLVA

AFR		m <sup>3</sup> /h		800											
		Indoor temperature													
		°CDB	16		18		20		22		24				
Outdoor temperature	°CDB	°CWB	TC	IP	TC	IP	TC	IP	TC	IP	TC	IP			
			kW		kW		kW		kW		kW				
	-15	-16	5.05	1.74	4.93	1.77	4.81	1.81	4.69	1.85	4.57	1.88			
	-10	-11	5.69	1.86	5.56	1.90	5.42	1.94	5.28	1.98	5.15	2.02			
	-5	-7	6.33	1.97	6.18	2.01	6.03	2.05	5.88	2.09	5.73	2.13			
	0	-2	6.97	2.08	6.81	2.13	6.64	2.17	6.47	2.21	6.31	2.26			
	5	3	7.61	2.20	7.43	2.24	7.25	2.29	7.07	2.34	6.89	2.38			
	7	6	7.88	2.24	7.69	2.28	7.50	2.33	7.31	2.38	7.13	2.42			
	10	8	8.51	2.32	8.30	2.37	8.10	2.42	7.90	2.47	7.70	2.52			
	15	10	8.46	2.04	8.26	2.09	8.06	2.13	7.86	2.17	7.66	2.20			
20	15	7.96	1.61	7.77	1.65	7.58	1.68	7.39	1.71	7.20	1.74				
24	18	8.40	1.60	8.20	1.64	8.00	1.67	7.80	1.70	7.60	1.73				

# Model: AUXG22KVL

AFR	m <sup>3</sup> /h	860
-----	-------------------	-----

		Indoor temperature											
		°CDB		16		18		20		22		24	
		°CDB	°CWB	TC	IP	TC	IP	TC	IP	TC	IP	TC	IP
Outdoor temperature			kW		kW		kW		kW		kW		
	-15	-16	5.60	2.16	5.46	2.21	5.33	2.25	5.20	2.30	5.06	2.34	
	-10	-11	6.14	2.25	6.00	2.29	5.85	2.34	5.70	2.39	5.56	2.43	
	-5	-7	6.70	2.32	6.54	2.37	6.38	2.42	6.22	2.47	6.06	2.52	
	0	-2	7.26	2.40	7.08	2.45	6.91	2.50	6.74	2.55	6.56	2.60	
	5	3	7.81	2.48	7.63	2.53	7.44	2.58	7.25	2.63	7.07	2.68	
	7	6	8.40	2.48	8.20	2.53	8.00	2.58	7.80	2.63	7.60	2.68	
	10	8	8.05	2.34	7.86	2.39	7.67	2.44	7.48	2.49	7.29	2.54	
	15	10	7.49	2.11	7.31	2.16	7.13	2.20	6.95	2.24	6.77	2.28	
	20	15	7.04	1.80	6.87	1.83	6.70	1.87	6.53	1.91	6.37	1.94	
24	18	7.32	1.78	7.14	1.81	6.97	1.85	6.80	1.89	6.62	1.92		

# 5. Fan performance

## 5-1. Air velocity distributions

### ■ Model: AUXG09KVLA (4-way air outlet)

Measuring conditions	Fan speed	Operation mode	Ceiling mode
	HIGH	FAN	STANDARD

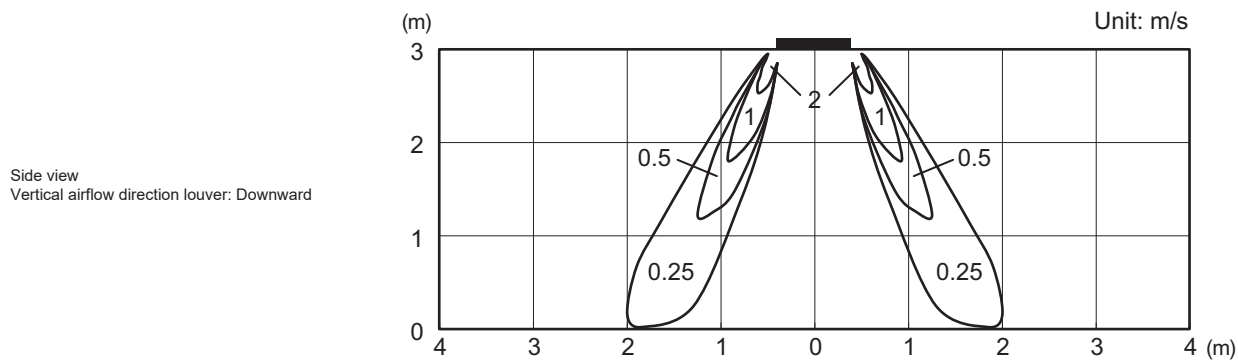
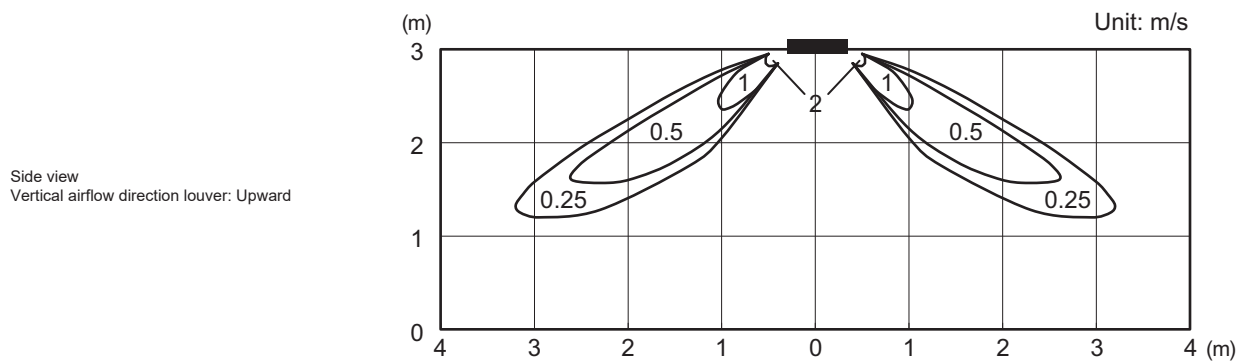
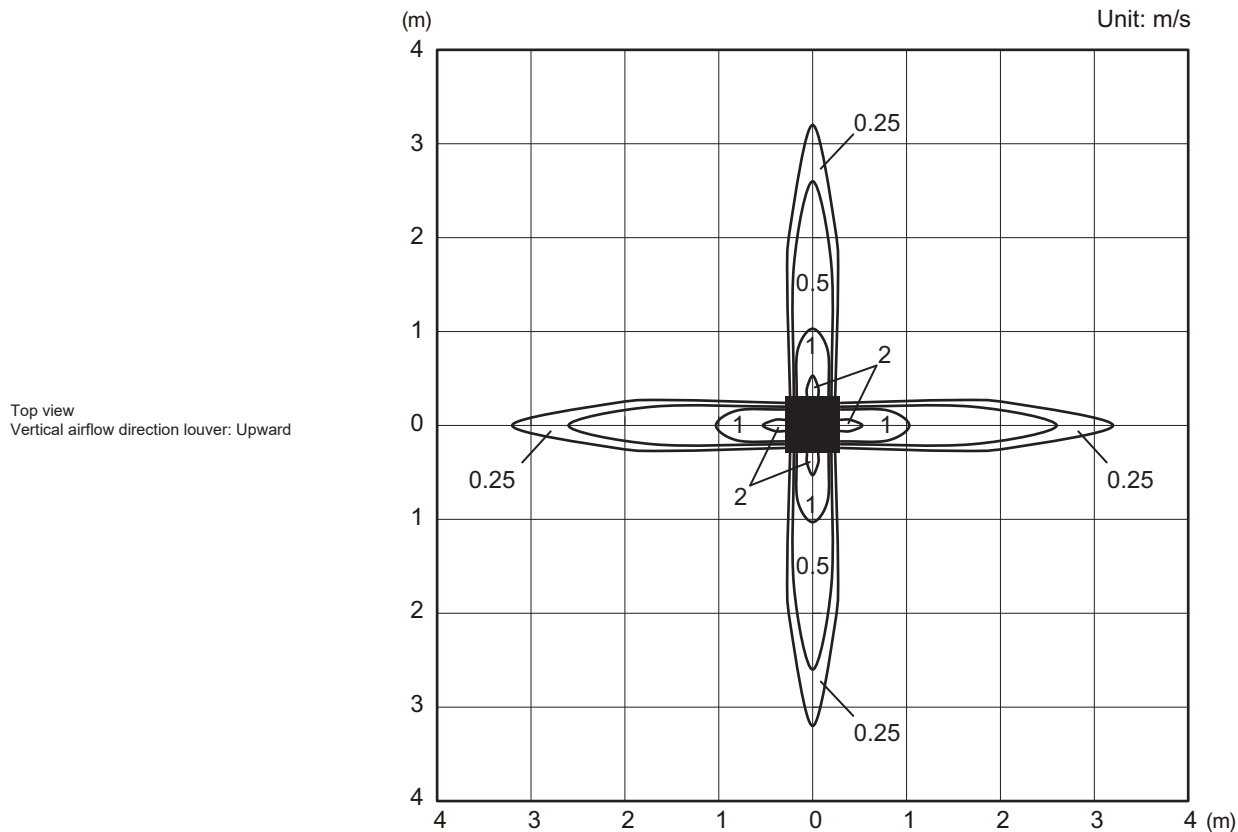

# Model: AUXG09KVLA (3-way air outlet)

Measuring conditions	Fan speed	Operation mode	Ceiling mode
	HIGH	FAN	STANDARD

Top view  
Vertical airflow direction louver: Upward

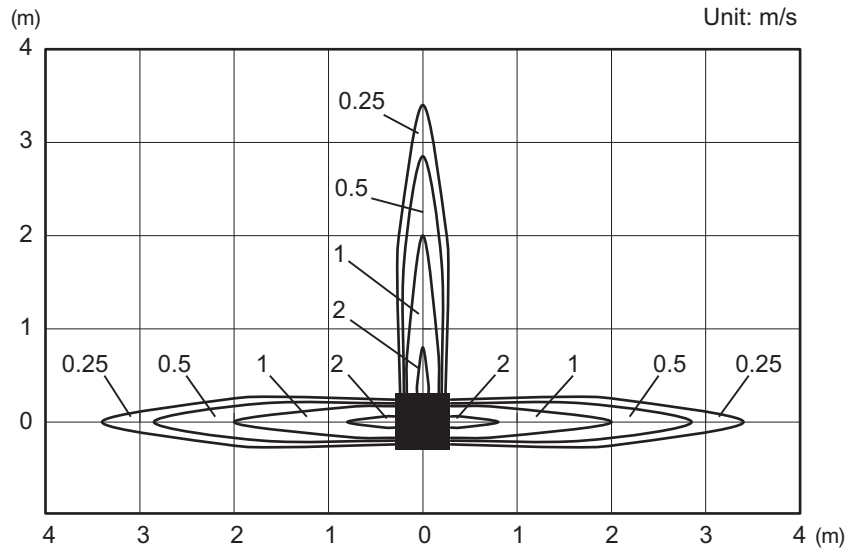

Side view  
Vertical airflow direction louver: Upward

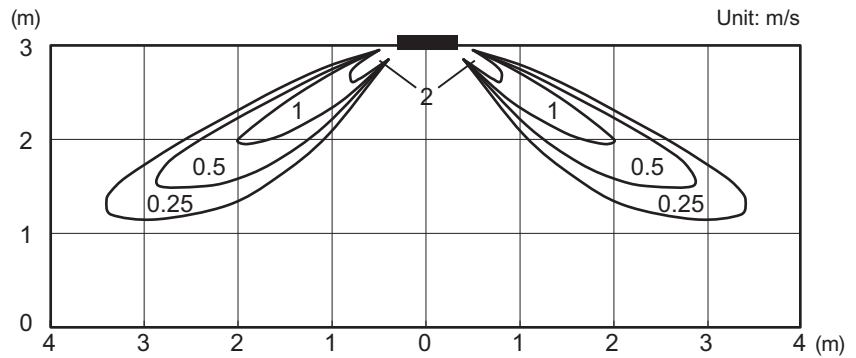

Side view  
Vertical airflow direction louver: Downward

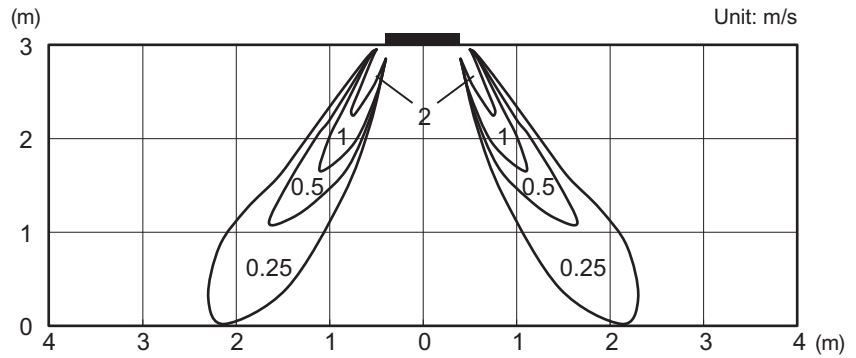

# Model: AUXG12KVLA (4-way air outlet)

CASSETTE TYPE  
AUXG09-22KVLA

CASSETTE TYPE  
AUXG09-22KVLA

Measuring conditions	Fan speed	Operation mode	Ceiling mode
	HIGH	FAN	STANDARD

Top view  
Vertical airflow direction louver: Upward

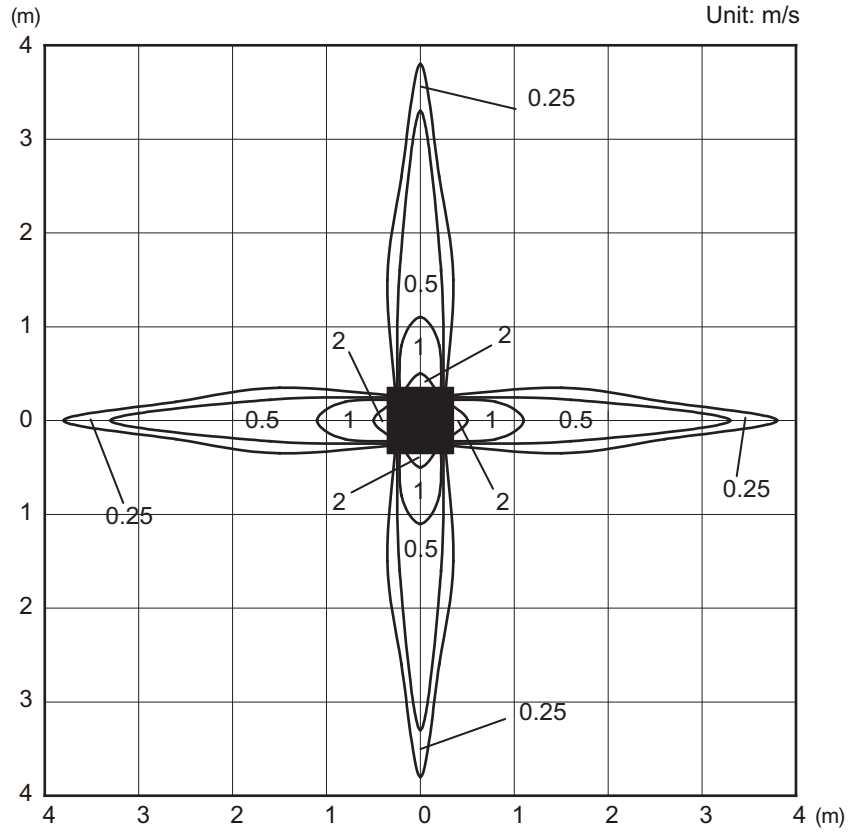

Side view  
Vertical airflow direction louver: Upward

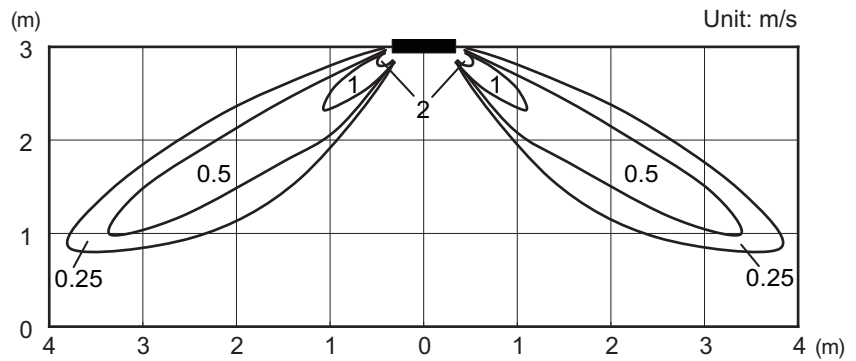

Side view  
Vertical airflow direction louver: Downward

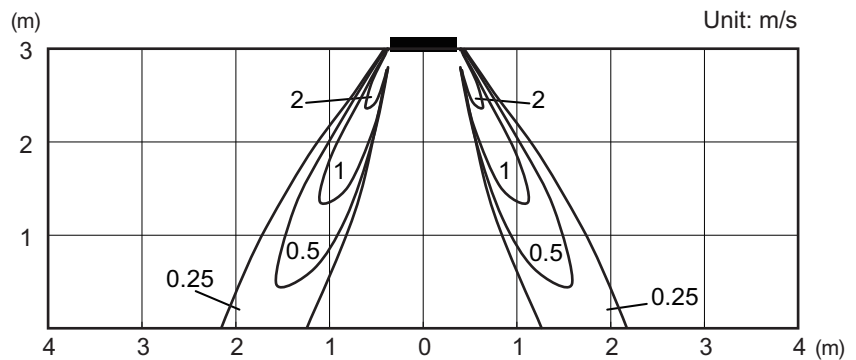

# Model: AUXG12KVLA (3-way air outlet)

CASSETTE TYPE  
AUXG09-22KVLA

CASSETTE TYPE  
AUXG09-22KVLA

Measuring conditions	Fan speed	Operation mode	Ceiling mode
	HIGH	FAN	STANDARD

Top view  
Vertical airflow direction louver: Upward

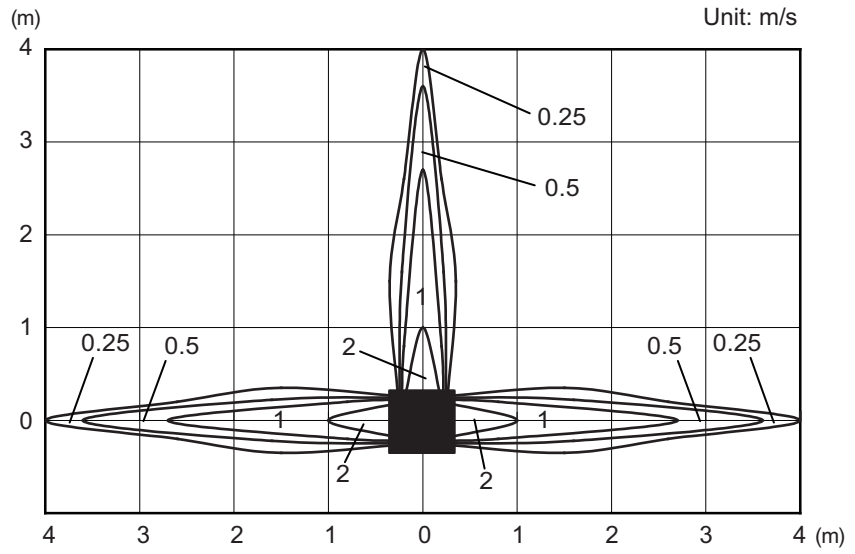

Side view  
Vertical airflow direction louver: Upward

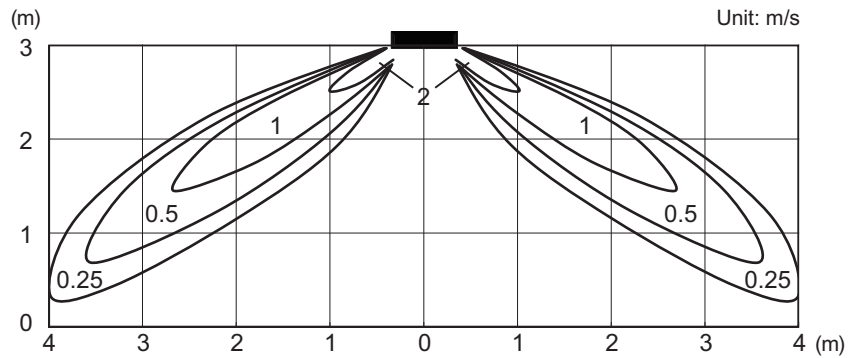

Side view  
Vertical airflow direction louver: Downward

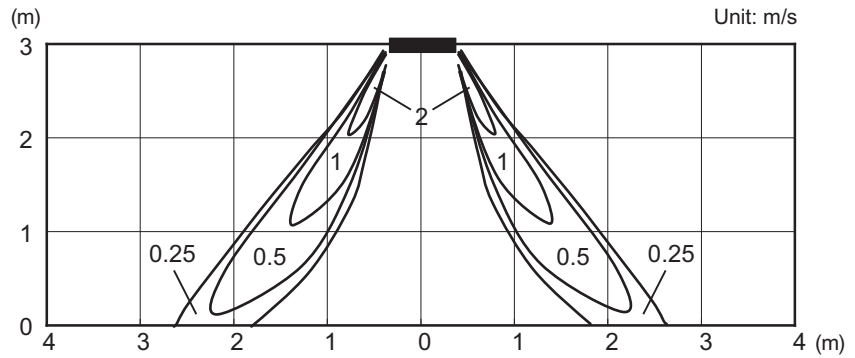

# Model: AUXG14KVLA (4-way air outlet)

CASSETTE TYPE  
AUXG09-22KVLA

CASSETTE TYPE  
AUXG09-22KVLA

Measuring conditions	Fan speed	Operation mode	Ceiling mode
	HIGH	FAN	STANDARD

Top view  
Vertical airflow direction louver: Upward

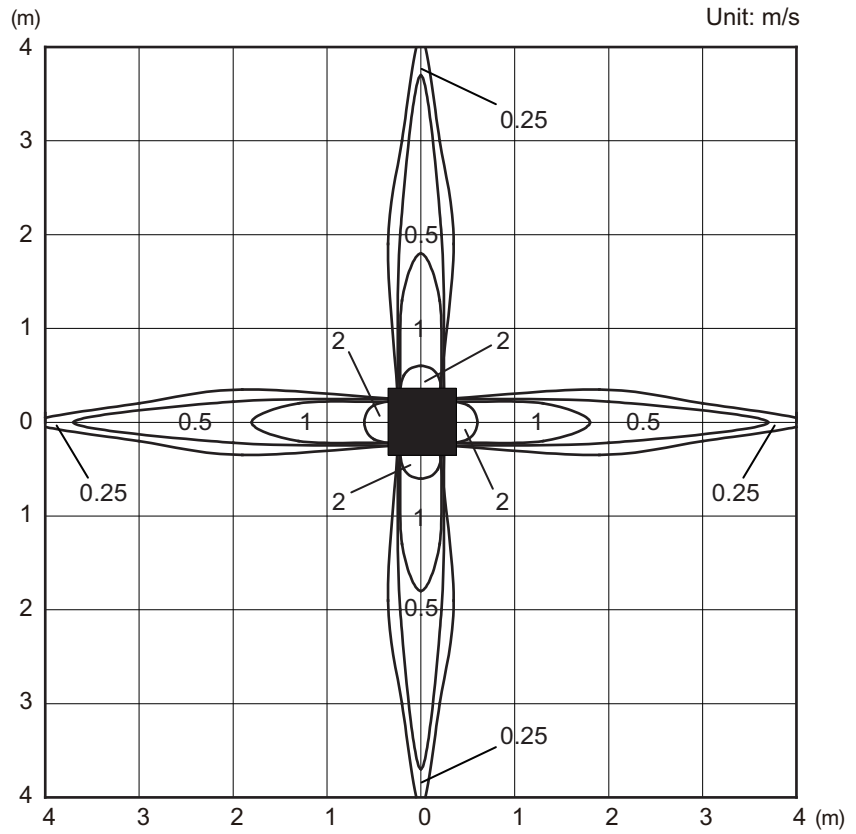

Side view  
Vertical airflow direction louver: Upward

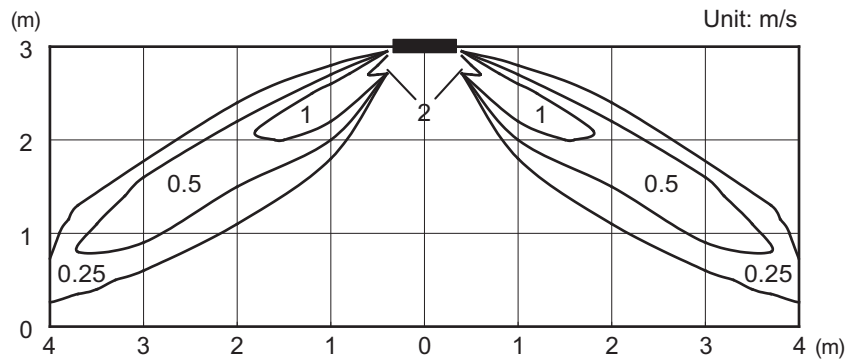

Side view  
Vertical airflow direction louver: Downward

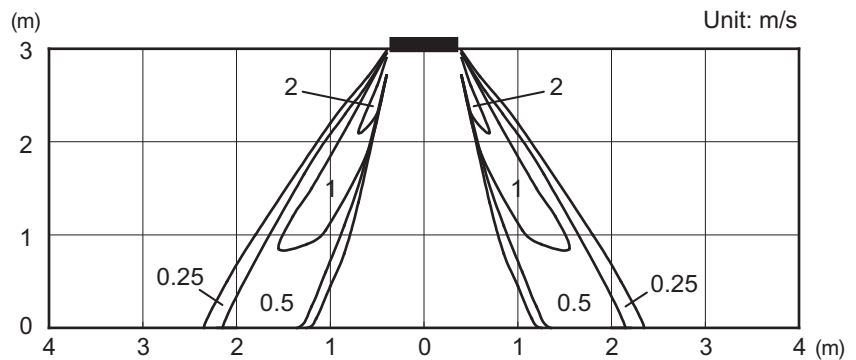

# Model: AUXG14KVLA (3-way air outlet)

CASSETTE TYPE  
AUXG09-22KVLA

CASSETTE TYPE  
AUXG09-22KVLA

Measuring conditions	Fan speed	Operation mode	Ceiling mode
	HIGH	FAN	STANDARD

Top view  
Vertical airflow direction louver: Upward

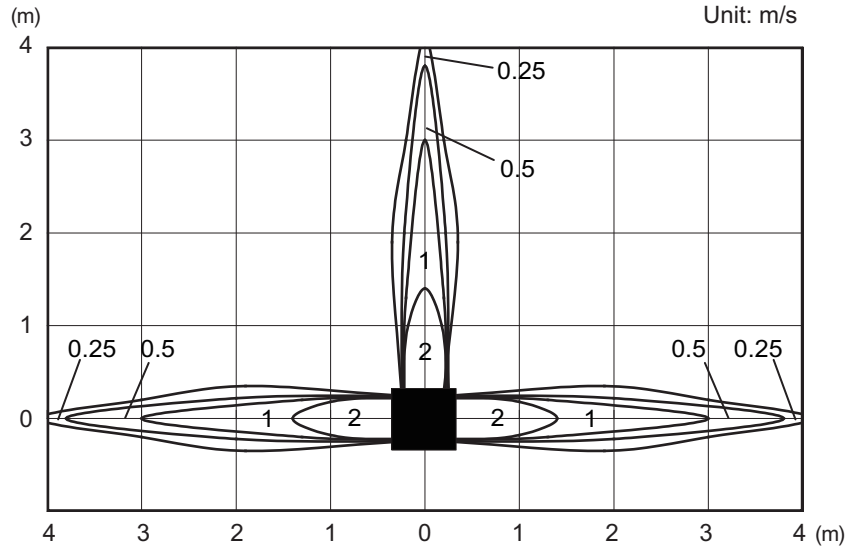

Side view  
Vertical airflow direction louver: Upward

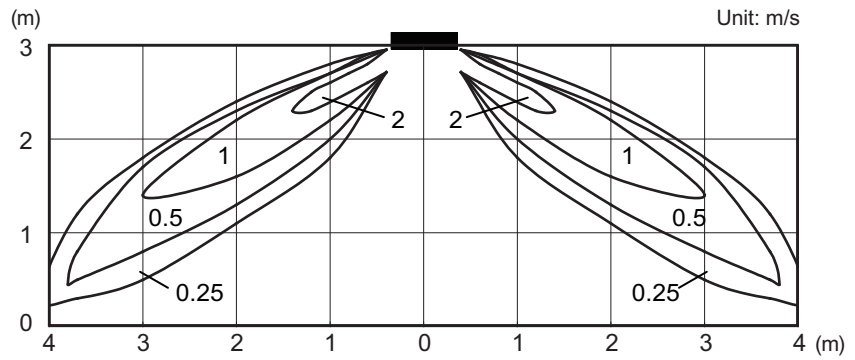

Side view  
Vertical airflow direction louver: Downward

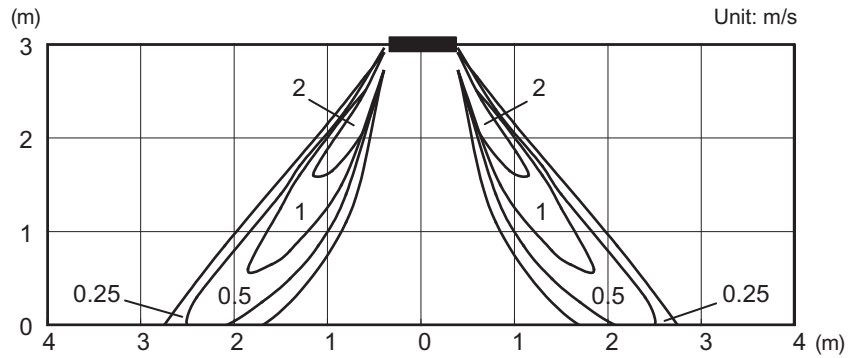

# Model: AUXG18KVLA (4-way air outlet)

Measuring conditions	Fan speed	Operation mode	Ceiling mode
	HIGH	FAN	STANDARD

Top view  
Vertical airflow direction louver: Upward

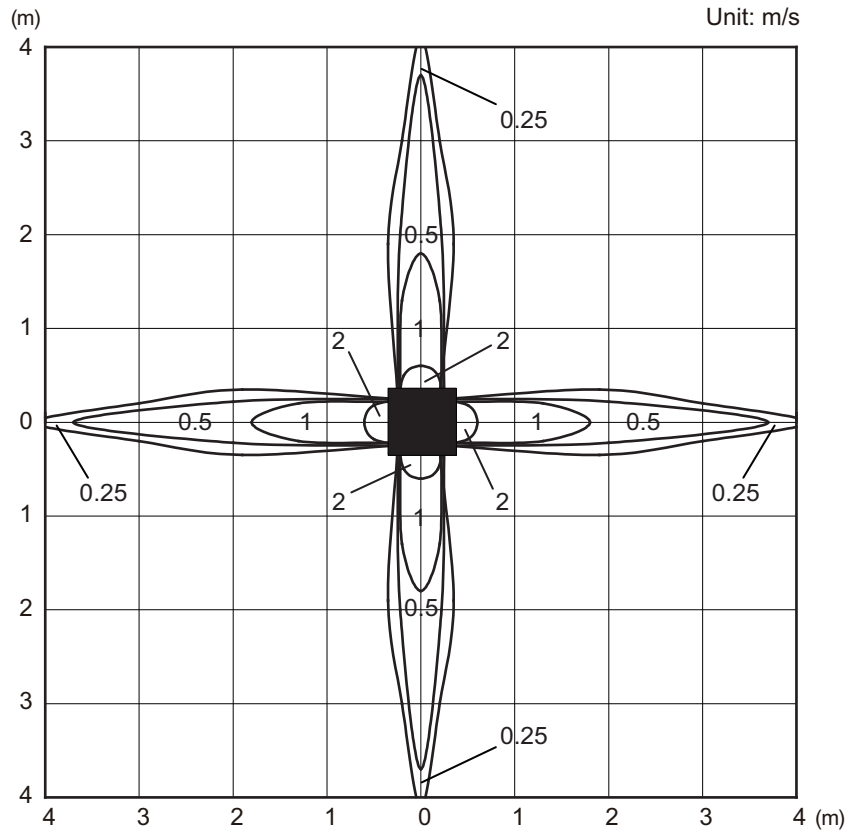

Side view  
Vertical airflow direction louver: Upward

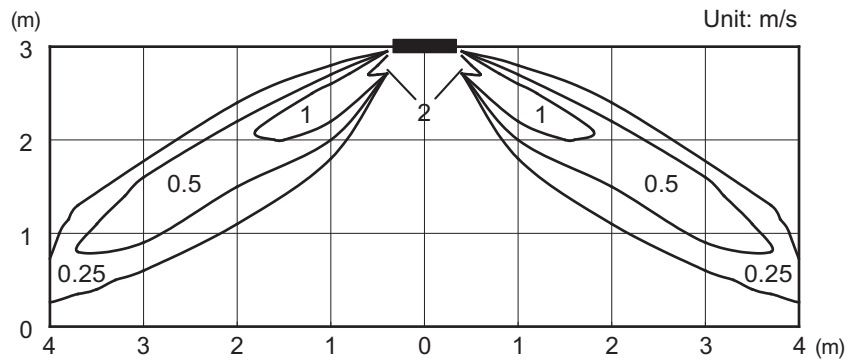

Side view  
Vertical airflow direction louver: Downward

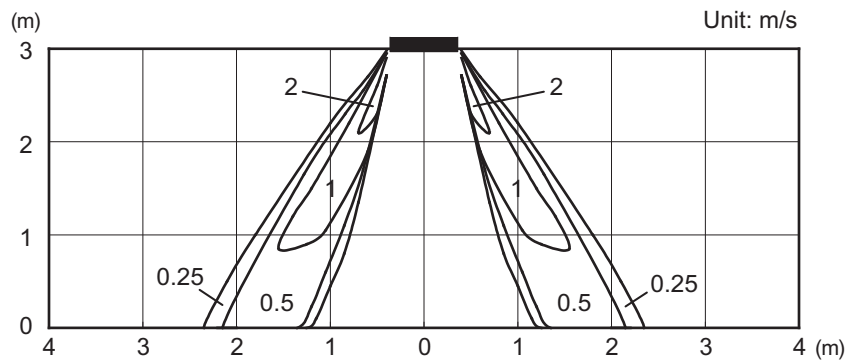

# Model: AUXG18KVL A (3-way air outlet)

CASSETTE TYPE  
AUXG09-22KVL A

CASSETTE TYPE  
AUXG09-22KVL A

Measuring conditions	Fan speed	Operation mode	Ceiling mode
	HIGH	FAN	STANDARD

Top view  
Vertical airflow direction louver: Upward

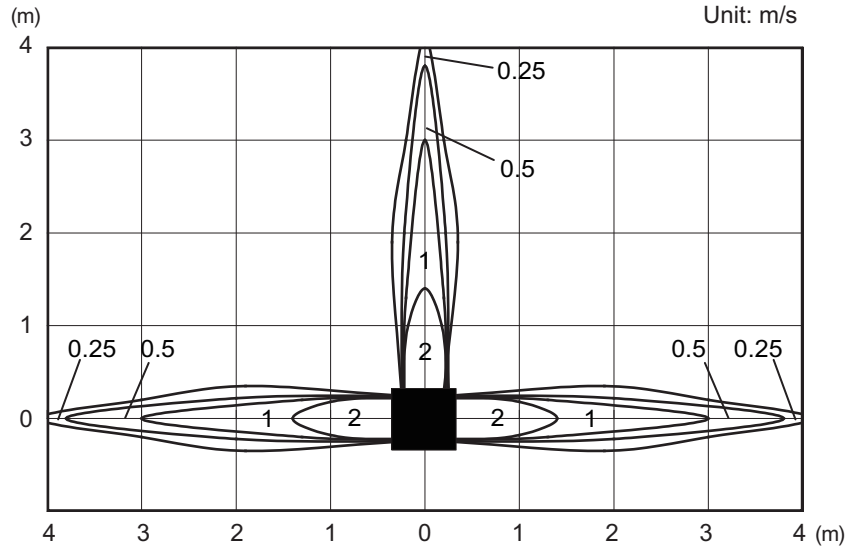

Side view  
Vertical airflow direction louver: Upward

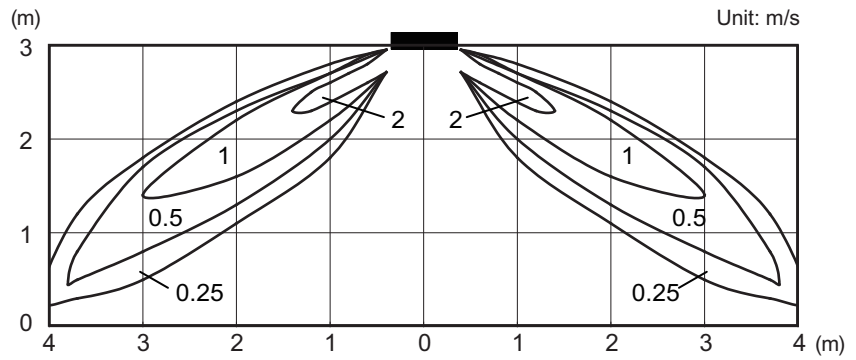

Side view  
Vertical airflow direction louver: Downward

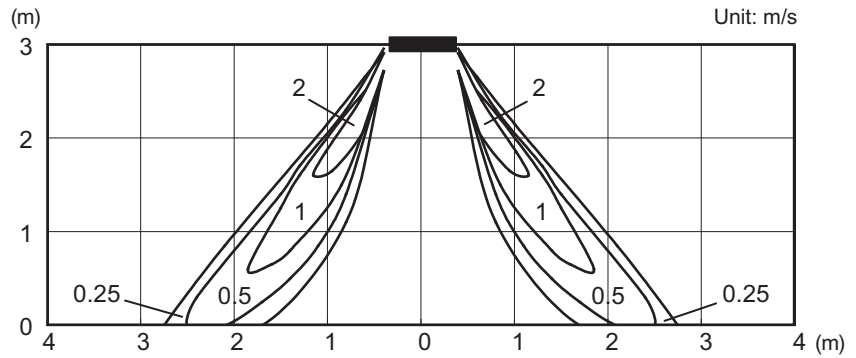

# Model: AUXG22KVLA (4-way air outlet)

CASSETTE TYPE  
AUXG09-22KVLA

CASSETTE TYPE  
AUXG09-22KVLA

Measuring conditions	Fan speed	Operation mode	Ceiling mode
	HIGH	FAN	STANDARD

Top view  
Vertical airflow direction louver: Upward

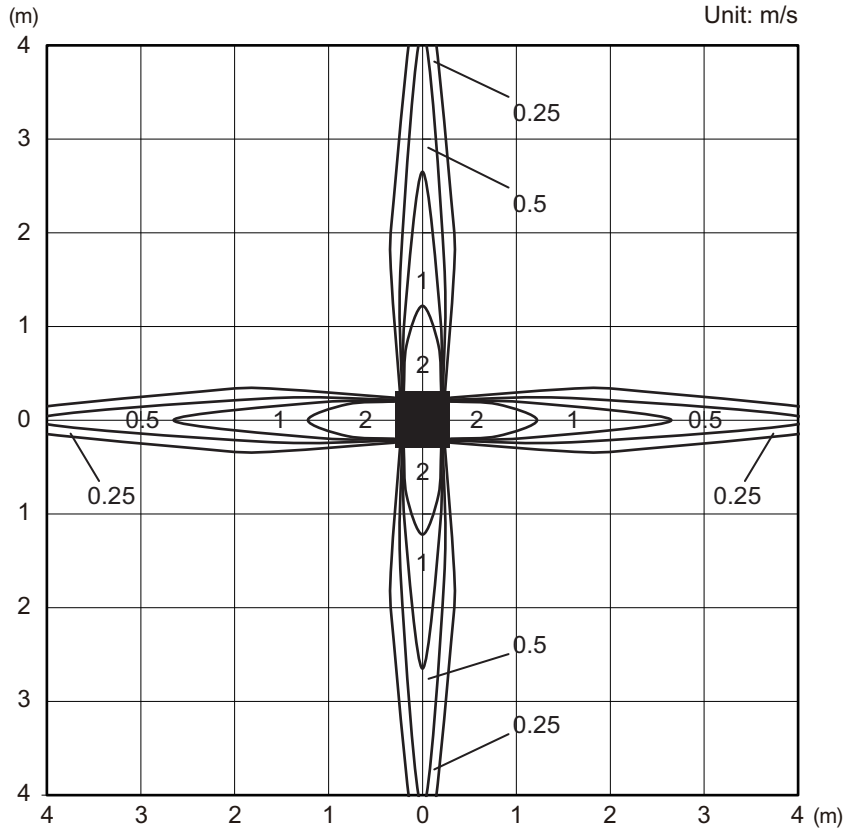

Side view  
Vertical airflow direction louver: Upward

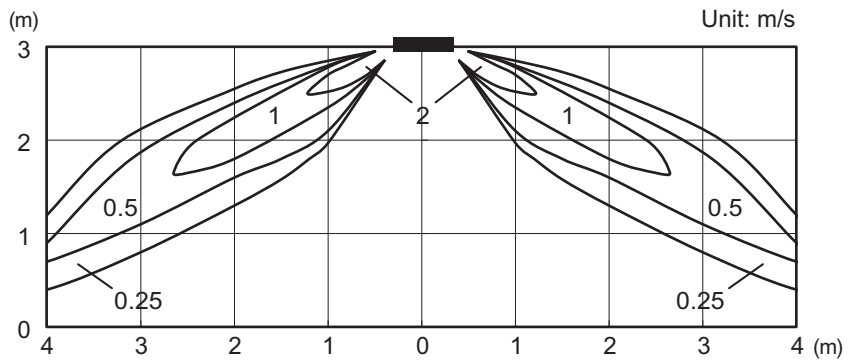

Side view  
Vertical airflow direction louver: Downward

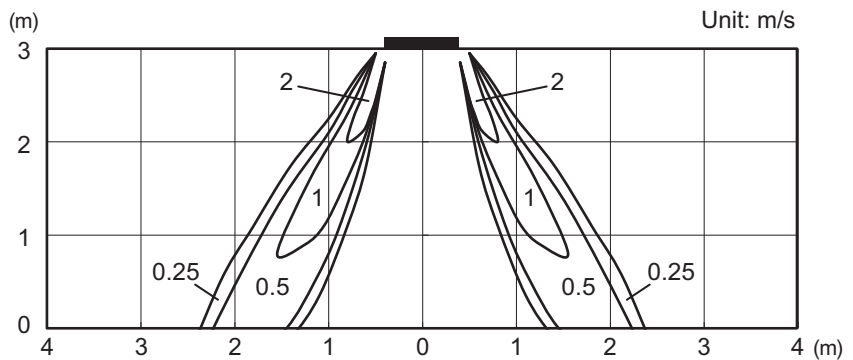

# Model: AUXG22KVL (3-way air outlet)

Measuring conditions	Fan speed	Operation mode	Ceiling mode
	HIGH	FAN	STANDARD

Top view  
Vertical airflow direction louver: Upward

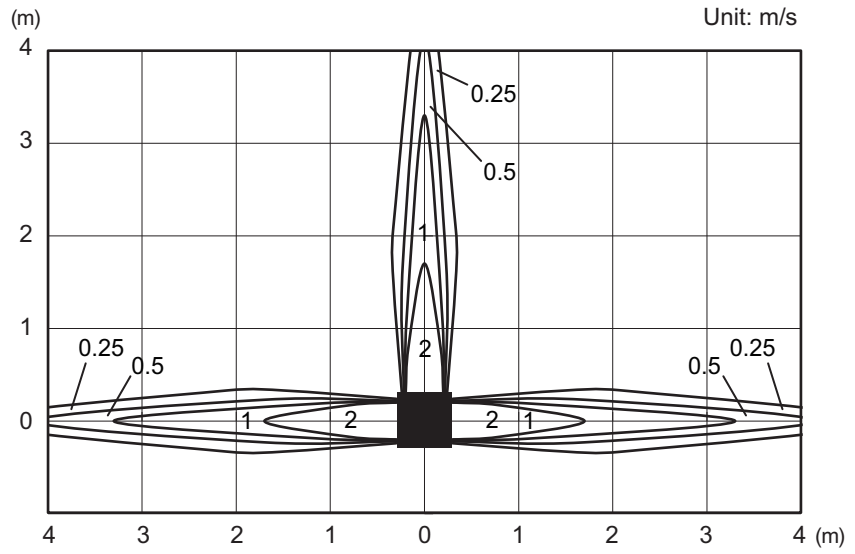

Side view  
Vertical airflow direction louver: Upward

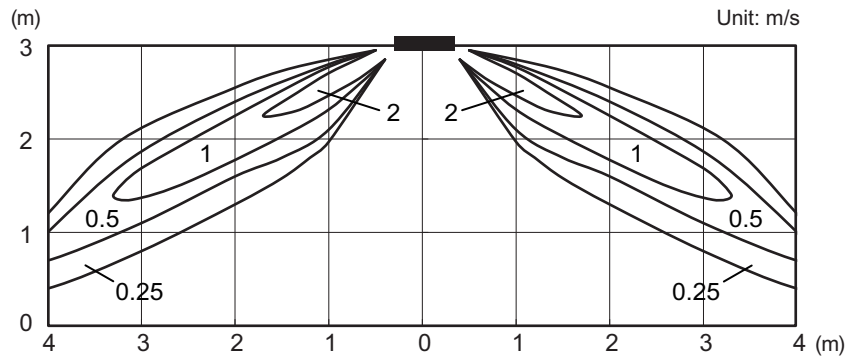

Side view  
Vertical airflow direction louver: Downward

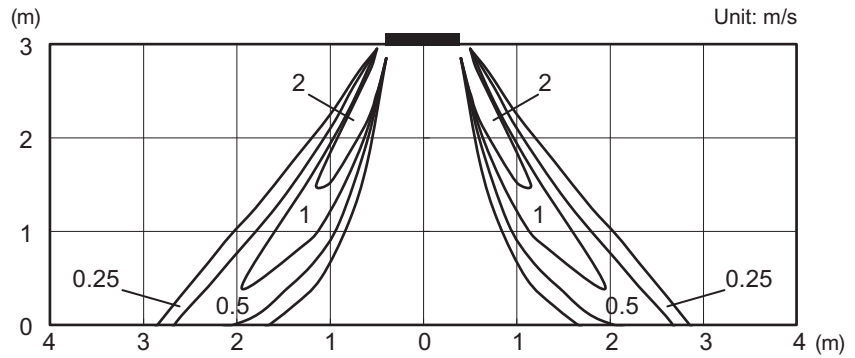

## 5-2. Airflow

### ■ Model: AUXG09KVLA

#### ● Cooling

Fan speed	Airflow	
HIGH	m <sup>3</sup> /h	540
	l/s	150
	CFM	318
MED	m <sup>3</sup> /h	490
	l/s	136
	CFM	288
LOW	m <sup>3</sup> /h	440
	l/s	122
	CFM	259
QUIET	m <sup>3</sup> /h	390
	l/s	108
	CFM	230

#### ● Heating

Fan speed	Airflow	
HIGH	m <sup>3</sup> /h	540
	l/s	150
	CFM	318
MED	m <sup>3</sup> /h	490
	l/s	136
	CFM	288
LOW	m <sup>3</sup> /h	440
	l/s	122
	CFM	259
QUIET	m <sup>3</sup> /h	390
	l/s	108
	CFM	230

## ■ Model: AUXG12KVLA

### ● Cooling

Fan speed	Airflow	
HIGH	m <sup>3</sup> /h	600
	l/s	167
	CFM	353
MED	m <sup>3</sup> /h	530
	l/s	147
	CFM	312
LOW	m <sup>3</sup> /h	470
	l/s	131
	CFM	277
QUIET	m <sup>3</sup> /h	410
	l/s	114
	CFM	241

### ● Heating

Fan speed	Airflow	
HIGH	m <sup>3</sup> /h	600
	l/s	167
	CFM	353
MED	m <sup>3</sup> /h	530
	l/s	147
	CFM	312
LOW	m <sup>3</sup> /h	470
	l/s	131
	CFM	277
QUIET	m <sup>3</sup> /h	410
	l/s	114
	CFM	241

## ■ Model: AUXG14KVLA

### ● Cooling

Fan speed	Airflow	
HIGH	m <sup>3</sup> /h	680
	l/s	189
	CFM	400
MED	m <sup>3</sup> /h	580
	l/s	161
	CFM	341
LOW	m <sup>3</sup> /h	490
	l/s	136
	CFM	288
QUIET	m <sup>3</sup> /h	410
	l/s	114
	CFM	241

### ● Heating

Fan speed	Airflow	
HIGH	m <sup>3</sup> /h	800
	l/s	222
	CFM	471
MED	m <sup>3</sup> /h	680
	l/s	189
	CFM	400
LOW	m <sup>3</sup> /h	580
	l/s	161
	CFM	341
QUIET	m <sup>3</sup> /h	450
	l/s	125
	CFM	265

## ■ Model: AUXG18KVLA

### ● Cooling

Fan speed	Airflow	
HIGH	m <sup>3</sup> /h	680
	l/s	189
	CFM	400
MED	m <sup>3</sup> /h	580
	l/s	161
	CFM	341
LOW	m <sup>3</sup> /h	490
	l/s	136
	CFM	288
QUIET	m <sup>3</sup> /h	410
	l/s	114
	CFM	241

### ● Heating

Fan speed	Airflow	
HIGH	m <sup>3</sup> /h	800
	l/s	222
	CFM	471
MED	m <sup>3</sup> /h	680
	l/s	189
	CFM	400
LOW	m <sup>3</sup> /h	580
	l/s	161
	CFM	341
QUIET	m <sup>3</sup> /h	450
	l/s	125
	CFM	265

## ■ Model: AUXG22KVLA

### ● Cooling

Fan speed	Airflow	
HIGH	m <sup>3</sup> /h	830
	l/s	231
	CFM	489
MED	m <sup>3</sup> /h	740
	l/s	206
	CFM	436
LOW	m <sup>3</sup> /h	600
	l/s	167
	CFM	353
QUIET	m <sup>3</sup> /h	450
	l/s	125
	CFM	265

### ● Heating

Fan speed	Airflow	
HIGH	m <sup>3</sup> /h	860
	l/s	239
	CFM	506
MED	m <sup>3</sup> /h	760
	l/s	211
	CFM	477
LOW	m <sup>3</sup> /h	700
	l/s	194
	CFM	412
QUIET	m <sup>3</sup> /h	530
	l/s	147
	CFM	312

# 6. Operation noise (sound pressure)

## 6-1. Noise level curve

### Model: AUXG09KVLA

#### ● Cooling

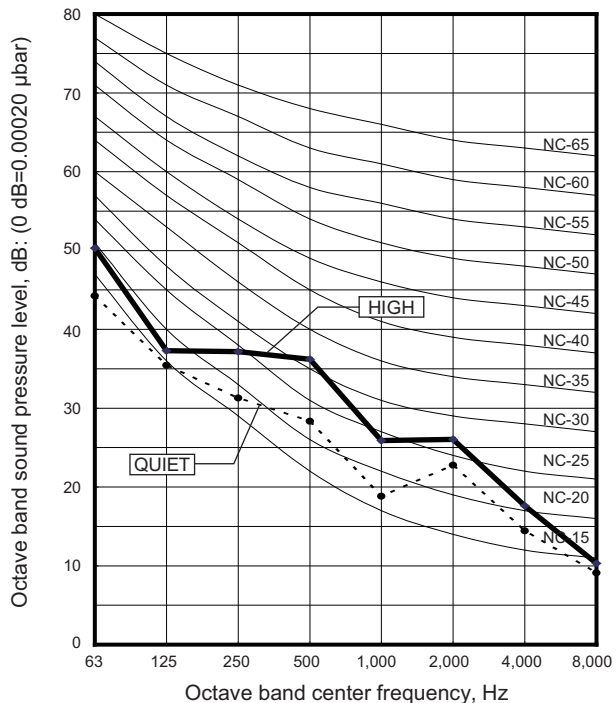

#### ● Heating

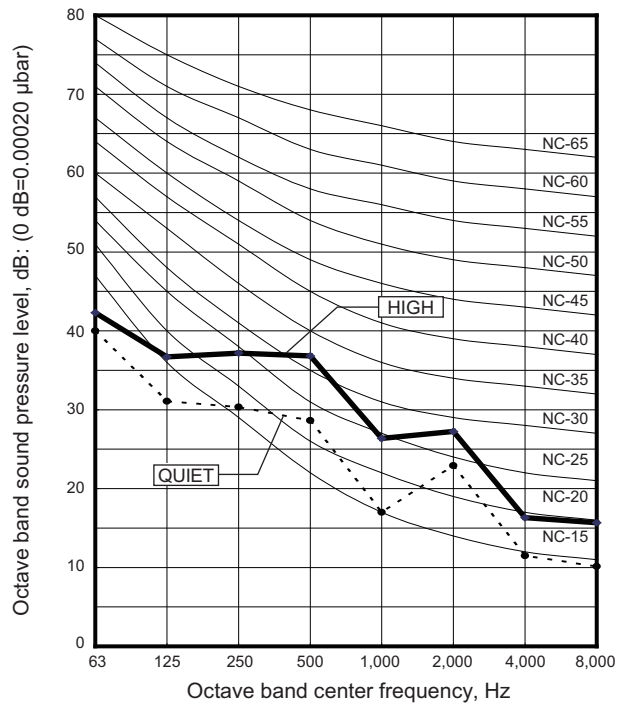

### Model: AUXG12KVLA

#### ● Cooling

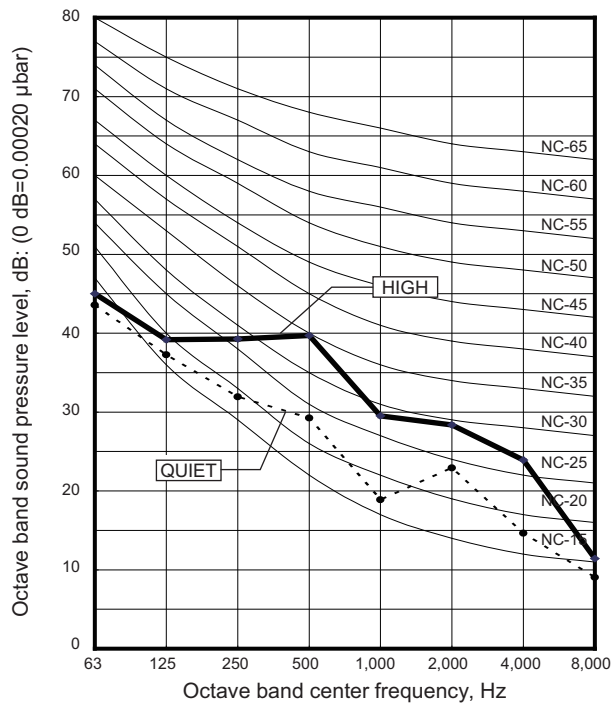

#### ● Heating

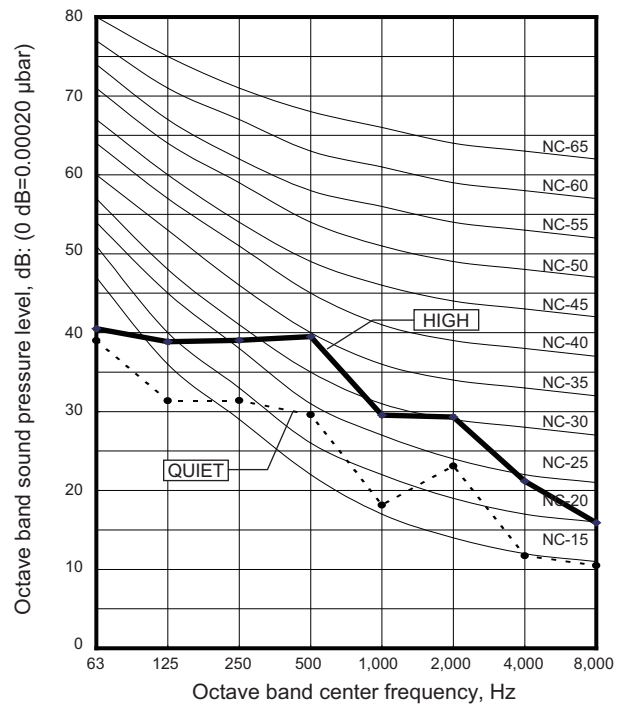

## Model: AUXG14KVL

### Cooling

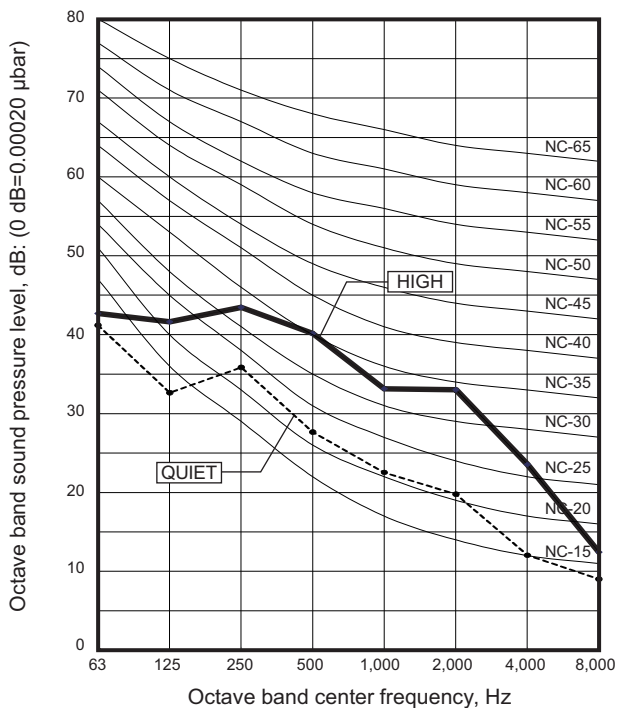

### Heating

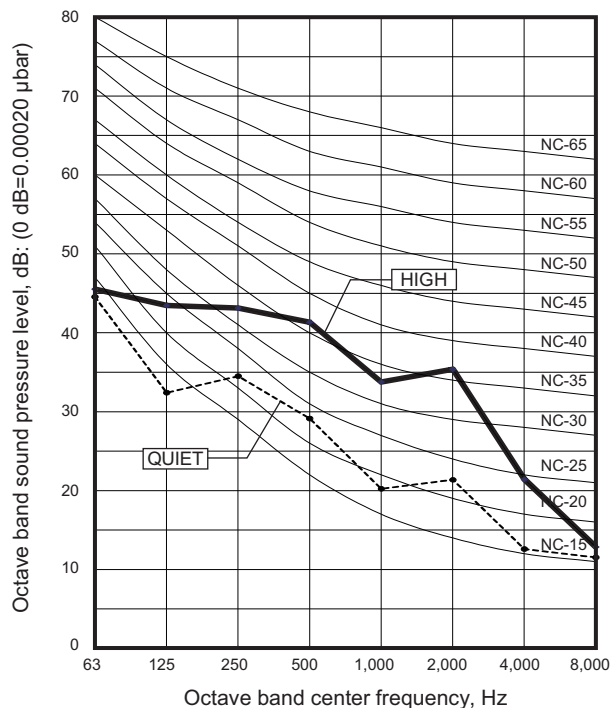

## Model: AUXG18KVL

### Cooling

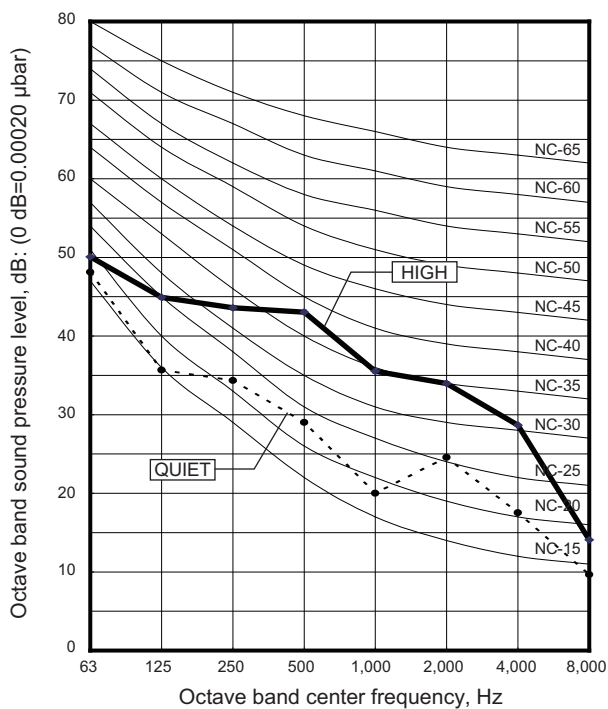

### Heating

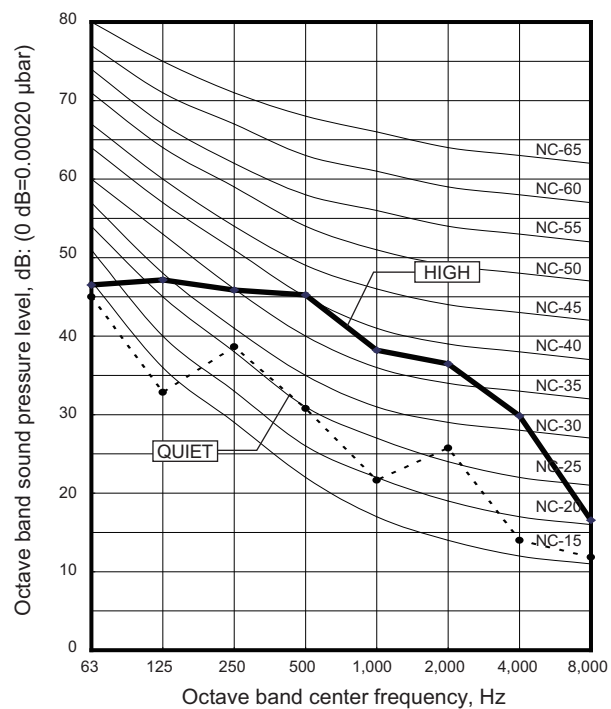

# Model: AUXG22KVLA

## ● Cooling

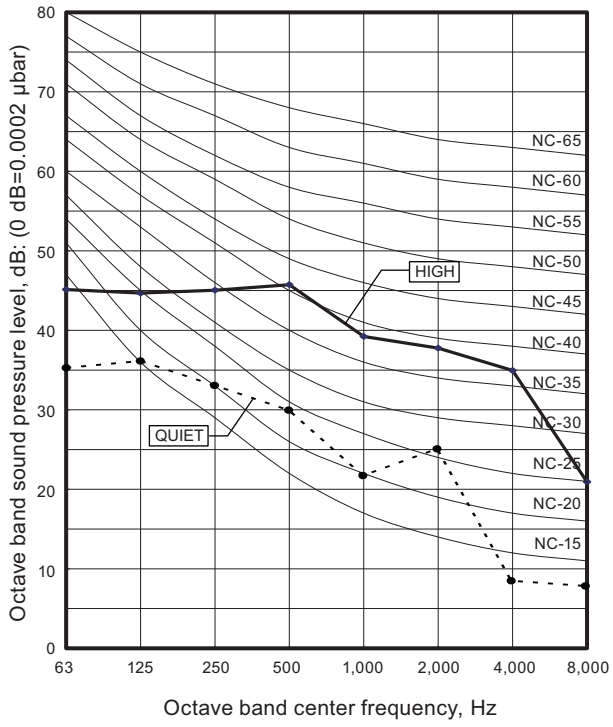

## ● Heating

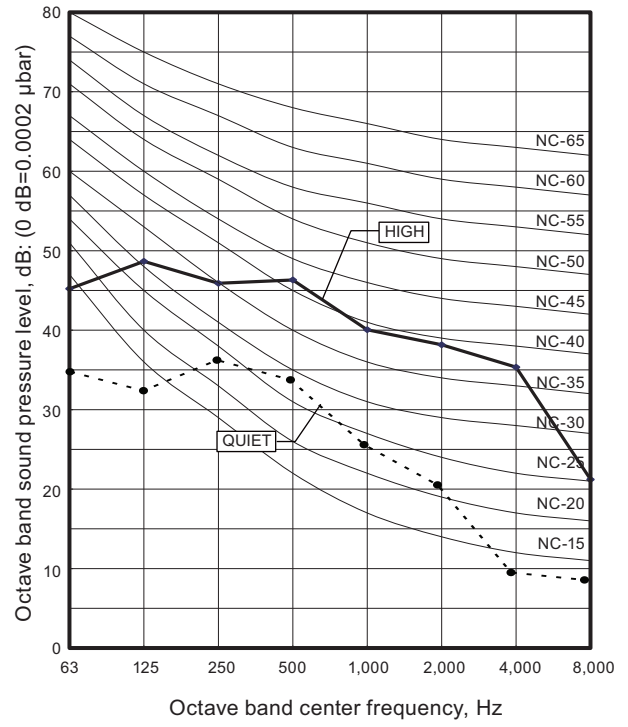

## 6-2. Sound level check point

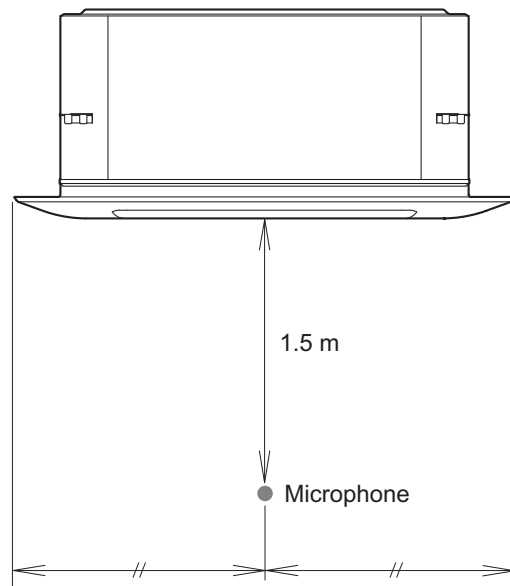
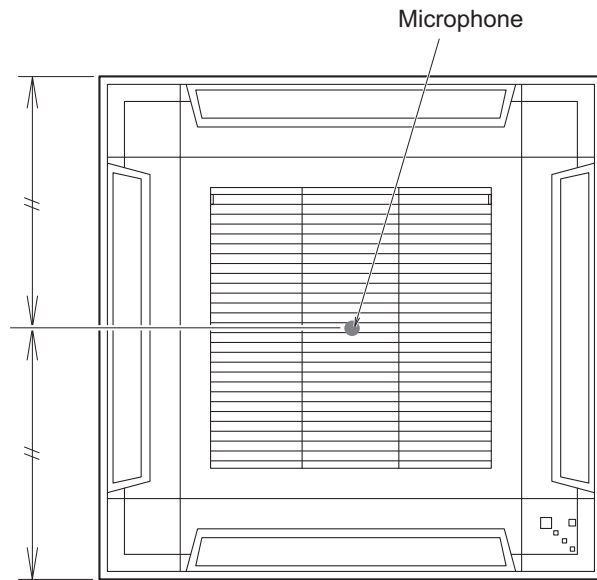

## 7. Safety devices

Type of protection	Protection form		Model
			AUXG09KVLA, AUXG12KVLA, AUXG14KVLA, AUXG18KVLA, and AUXG22KVLA
Circuit protection	Current fuse (PCB*)		250 V, 5 A
Fan motor protection	Thermal protection program	Activate	100 ± 10 °C Fan motor stop
		Reset	95 ± 10 °C Fan motor restart

\*PCB: Printed Circuit Board

## 8. External input and output

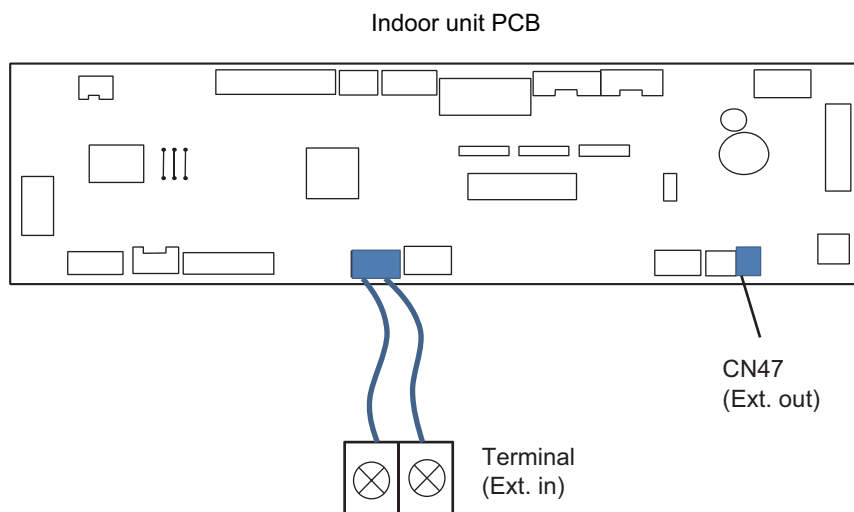

External input and output		Connector	Input select	Input signal	External connect kit (Optional parts)
External input	Operation/Stop Forced stop	Terminal	Dry contact	Edge	—
External output	Operation status	CN47	—	—	UTY-XWZXZG
	Error status				
	Indoor unit fan operation status				
	External heater output				

### 8-1. External input

- “Operation/Stop” mode or “Forced stop” mode can be selected with function setting of indoor unit.
- A twisted pair cable (22AWG) should be used. Maximum length of cable is 150 m.
- The wire connection should be separate from the power cable line.

Indoor unit functions such as Operation/Stop can be done by using indoor unit terminals.

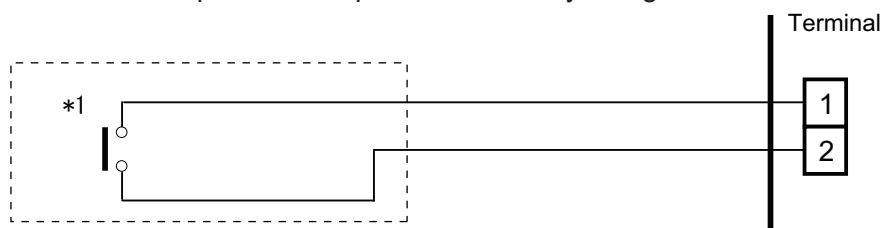

\*1: The switch can be used on the following condition: DC 12 V to 24 V, 1 mA to 15 mA.

## 8-2. External output

Use an external output cable with appropriate external dimension, depending on the number of cables to be installed.

- A twisted pair cable (22AWG) should be used. Maximum length of cable is 25 m.
- Output voltage: High DC 12 V  $\pm$  2 V, Low 0 V.
- Permissible current: 50 mA
- For details, refer to "[Combination of external input and output](#)" on page 35.

### ● When indicator, etc. are connected directly

**Example:** Function setting 60 is set to "00"

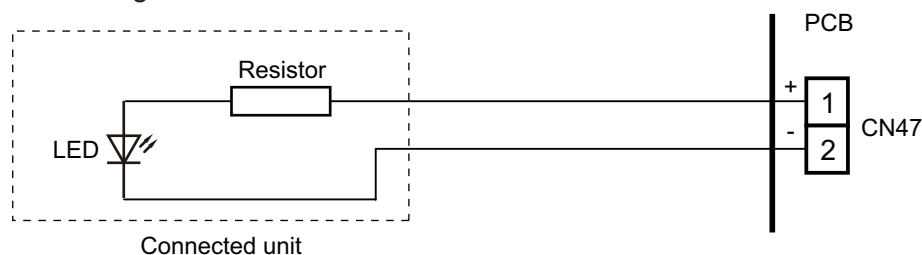

### ● When connecting with a device equipped with a power supply

**Example:** Function setting 60 is set to "00"

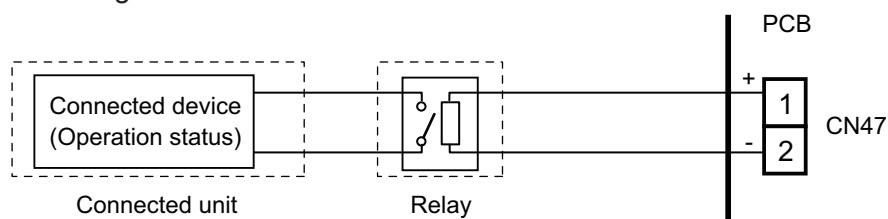

## 8-3. Combination of external input and output

By combining the function setting of the indoor unit, you can select various combinations of functions.

Combination examples of external input and output are as follows:

Mode	Function setting	External input	External output
		Terminal	CN47
0	60—00	Operation/Stop	
1—8	60—01 to 60—08	(Setting prohibited)	
9	60—09	Operation/Stop	Error status
10	60—10	Operation/Stop	Indoor unit fan operation status
11	60—11	Operation/Stop	External heater output

**NOTE:** Input of Operation/Stop depends on the setting of function setting 46.

- 00: Operation/Stop mode 1 (R.C. enabled)
- 01: (Setting prohibited)
- 02: Forced stop
- 03: Operation/Stop mode 2 (R.C. disabled)

### ■ Input signal type

- Indoor unit  
Input signal type is only "Edge".



## 8-4. Details of function

### ■ Control input function

- When function setting is "Operation/Stop" mode 1

Function setting	External input	Input signal	Command
46—00	Terminal	Off → On	Operation
		On → Off	Stop

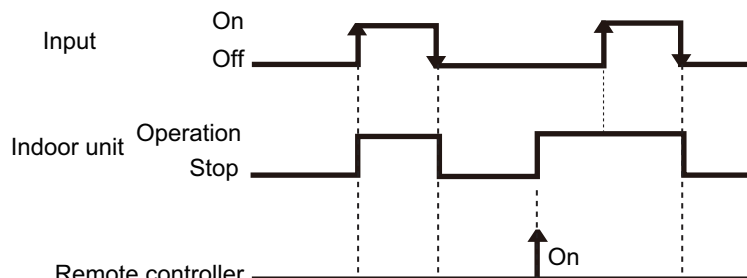

#### NOTES:

- The last command has priority.
- The indoor units within the same remote controller group operates in the same mode.

- When function setting is "Forced stop" mode

Function setting	External input	Input signal	Command
46—02	Terminal	Off → On	Forced stop
		On → Off	Normal

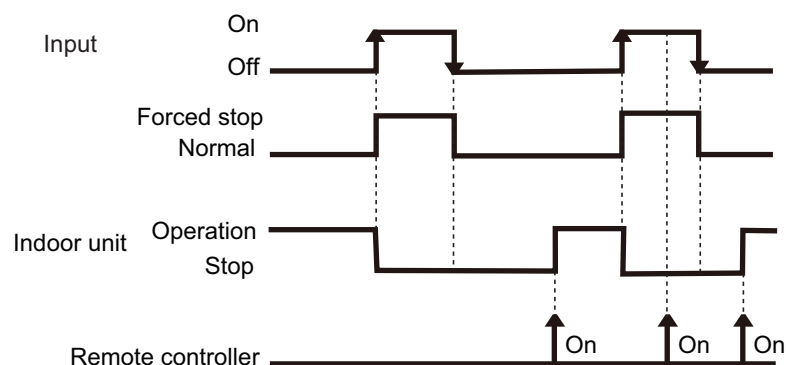

#### NOTES:

- When the forced stop is triggered, indoor unit stops and Operation/Stop operation by the remote controller is restricted.
- When forced stop function is used with forming a remote controller group, connect the same equipment to each indoor unit within the group.

- When function setting is "Operation/Stop" mode 2

Function setting	External input	Input signal	Command
46—03	Terminal	Off → On	Operation
		On → Off	Stop (R.C. disabled)

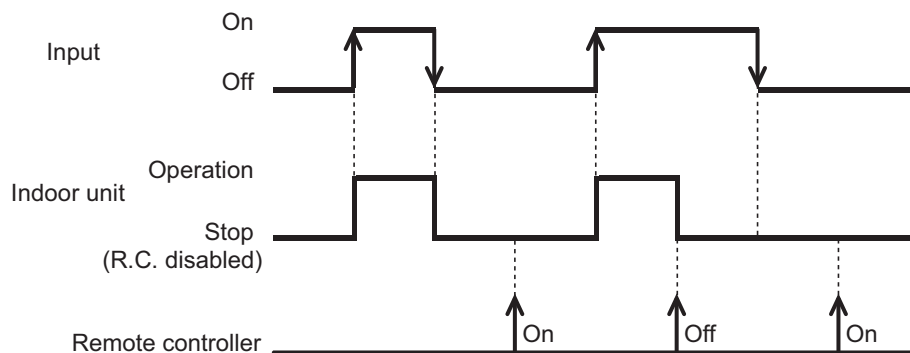

**NOTE:** When "Operation/Stop" mode 2 function is used with forming a remote controller group, connect the same equipment to each indoor unit within the group.

## Control output function

Function setting	External output	Output signal	Command
60—00	CN47	Low → High	Operation
		High → Low	Stop

The output is low when the unit is stopped.

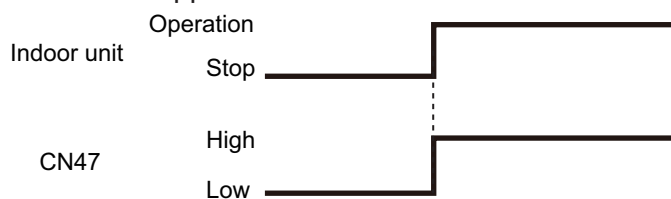

## Error status

Function setting	External output	Output signal	Command
60—09	CN47	Low → High	Error
		High → Low	Normal

The output is ON when an error is generated for the indoor unit.

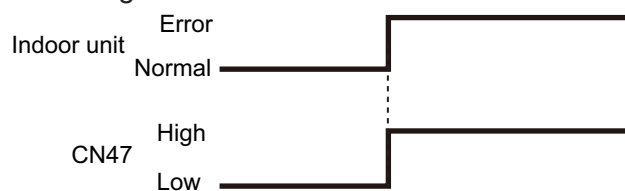

## Indoor unit fan operation status

Function setting	External output	Output signal	Command
60—10	CN47	Low → High	Fan run
		High → Low	Fan stop

Output signal	Condition
On	The indoor unit fan is operating.
Low → High	
Off	The fan is stopped or during cold air prevention. During thermostat off when in dry mode operation.
High → Low	

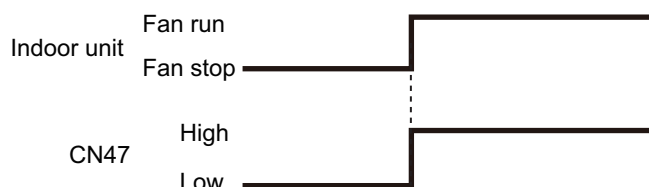

## External heater output

Function setting	External output	Output signal	Command
60—11	CN47	Low → High	Heater on
		High → Low	Heater off

Output signal	Condition
Low → High	Heater turns on as shown in diagram of heating temperature
Off → On	
High → Low	Heater turns off as shown in diagram of heating temperature
On → Off	<ul style="list-style-type: none"> <li>• Other than Heating mode</li> <li>• Error occurred</li> <li>• Forced thermo off</li> <li>• Fan stop protection</li> </ul>

Specifications of the signal output performance are as shown as follows:

**Example** When set temperature ( $T_s$ ) is set at 22 °C;

- And room temperature ( $T_r$ ) increase above 12 °C, signal output is on.
- And  $T_r$  increase above 21 °C, signal output is off.
- And  $T_r$  decrease below 19 °C, signal output is on.
- And  $T_r$  decrease below 10 °C, signal output is off.

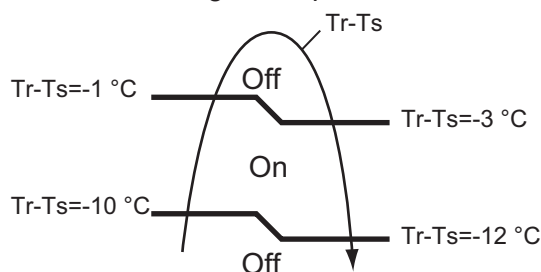

The output also turns off in defrost operation.

## 9. Function settings

To adjust the functions of this product according to the installation environment, various types of function settings are available.

**NOTE:** Incorrect settings can cause a product malfunction.

### 9-1. Function settings on indoor unit

By using some components on the PCB, you can change the function settings.

#### ■ Component location

Components on the indoor unit main PCB used for the function settings are located as shown in the following figure.

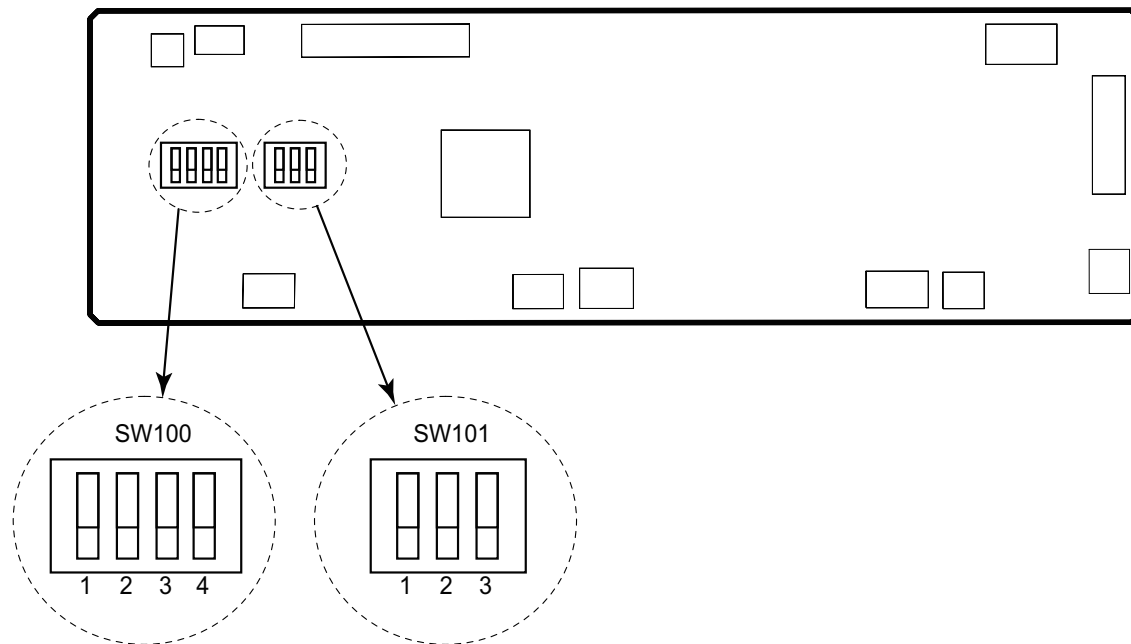

## ■ DIP switch setting

### • SW100: Remote controller address setting

**NOTE:** Because this setting is normally done automatically when 2-core wired remote controller is installed, setting is unnecessary.

Multiple indoor units can be operated by using one wired remote controller.  
Set the unit number of each indoor unit.

Remote controller address	DIP switch number				Factory setting
	1	2	3	4	
00	OFF	OFF	OFF	OFF	◆
01	ON	OFF	OFF	OFF	
02	OFF	ON	OFF	OFF	
03	ON	ON	OFF	OFF	
04	OFF	OFF	ON	OFF	
05	ON	OFF	ON	OFF	
06	OFF	ON	ON	OFF	
07	ON	ON	ON	OFF	
08	OFF	OFF	OFF	ON	
09	ON	OFF	OFF	ON	
10	OFF	ON	OFF	ON	
11	ON	ON	OFF	ON	
12	OFF	OFF	ON	ON	
13	ON	OFF	ON	ON	
14	OFF	ON	ON	ON	
15	ON	ON	ON	ON	

#### NOTES:

- When connecting Polar 3-core wired remote controller, set the remote controller address in the order of 0, 1, 2, ....., and 15.
- When different type of indoor units (such as wall-mounted type and cassette type, cassette type and duct type, or other combinations) are connected using group control system, some functions may no longer be available.

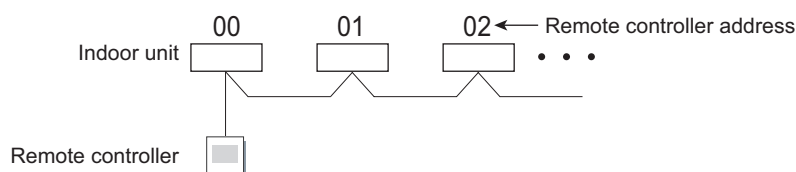

### • SW101: Setting change prohibited

## 9-2. Function settings by using remote controller

Some function settings can be changed on the remote controller. After confirming the setting procedure and the content of each function setting, select appropriate functions for your installation environment.

### ■ Setting procedure by using remote controller

Remote controller is not attached for this product. For details of the installing remote controller, refer to following information.

- Overview information: Operating manual of the remote controller
- Setting procedure: Installation manual of the remote controller

### ■ Contents of function setting

Each function setting listed in this section is adjustable in accordance with the installation environment.

**NOTE:** Setting will not be changed if invalid numbers or setting values are selected.

### ● Function setting list

	Function no.	Functions
1)	11	Filter sign
2)	20	Ceiling height
3)	22	Outlet directions
4)	30/31	Room temperature control for indoor unit sensor
5)	35/36	Room temperature control for wired remote controller sensor
6)	40	Auto restart
7)	42	Room temperature sensor switching
8)	44	Remote controller custom code
9)	46	External input control
10)	48	Room temperature sensor switching (Aux.)
11)	49	Indoor unit fan control for energy saving for cooling
12)	60	Switching functions for external output terminal

#### 1) Filter sign

Select appropriate intervals for displaying the filter sign on the indoor unit according to the estimated amount of dust in the air of the room.

If the indication is not required, select "No indication" (03).

Function number	Setting value	Setting description	Factory setting
11	00	Standard (2,500 hours)	
	01	Long interval (4,400 hours)	
	02	Short interval (1,250 hours)	
	03	No indication	◆

## 2) Ceiling height

Select the appropriate ceiling height according to the place of installation.

Function number	Setting value	Setting description	Factory setting
20	00	Standard	◆
	01	High ceiling	

For the specific height for each setting value, refer to "Installation space" in Chapter 2. "[Dimensions](#)" on page 6.

### In case of cassette type models:

The ceiling height values are for the 4-way outlet. Do not change this setting in the 3-way outlet mode.

9,000 Btu/h model cannot be installed in high ceiling. Do not change this setting.

## 3) Outlet directions

Select the appropriate number of outlet directions according to the installation conditions.

Function number	Setting value	Setting description	Factory setting
22	00	4-way	◆
	01	3-way	

#### 4) Room temperature control for indoor unit sensor

Depending on the installed environment, correction of the room temperature sensor may be required. Select the appropriate control setting according to the installed environment.

The temperature of the room temperature sensor is corrected as follows:

Corrected temp. = Temp. of the room temp. sensor - Correction temp. value

Example of correction:

When the temperature of the room temp. sensor is 26°C and the setting value is "03" (-1.0°C), corrected temp. will be 27°C (26°C - [-1.0°C]).

The temperature correction values show the difference from the Standard setting "00" (manufacturer's recommended value).

Function number		Setting value	Setting description	Factory setting	
30 (For cooling)	31 (For heating)	00	Standard setting	◆	
		01	No correction 0.0 °C		
		02	-0.5 °C	More cooling Less heating	
		03	-1.0 °C		
		04	-1.5 °C		
		05	-2.0 °C		
		06	-2.5 °C		
		07	-3.0 °C		
		08	-3.5 °C		
		09	-4.0 °C		
		10	+0.5 °C	Less cooling More heating	
		11	+1.0 °C		
		12	+1.5 °C		
		13	+2.0 °C		
		14	+2.5 °C		
		15	+3.0 °C		
		16	+3.5 °C		
17	+4.0 °C				

### 5) Room temperature control for wired remote controller sensor

Depending on the installed environment, correction of the wire remote temperature sensor may be required. Select the appropriate control setting according to the installed environment.

To change this setting, set Function 42 to Both "01".

Ensure that the Thermo Sensor icon is displayed on the remote controller screen.

Function number		Setting value	Setting description	Factory setting	
35 (For cooling)	36 (For heating)	00	Standard setting	◆	
		01	No correction 0.0°C		
		02	-0.5 °C	More cooling Less heating	
		03	-1.0 °C		
		04	-1.5 °C		
		05	-2.0 °C		
		06	-2.5 °C		
		07	-3.0 °C		
		08	-3.5 °C		
		09	-4.0 °C		
		10	+0.5 °C	Less cooling More heating	
		11	+1.0 °C		
		12	+1.5 °C		
		13	+2.0 °C		
		14	+2.5 °C		
		15	+3.0 °C		
		16	+3.5 °C		
17	+4.0 °C				

### 6) Auto restart

Enables or disables automatic restart after a power interruption.

Function number	Setting value	Setting description	Factory setting
40	00	Enable	◆
	01	Disable	

**NOTE:** Auto restart is an emergency function such as for power outage etc. Do not attempt to use this function in normal operation. Be sure to operate the unit by remote controller or external device.

### 7) Room temperature sensor switching

(Only for wired remote controller)

When using the wired remote controller temperature sensor, change the setting to "Both" (01).

Function number	Setting value	Setting description	Factory setting
42	00	Indoor unit	◆
	01	Both	

00: Sensor on the indoor unit is active.

01: Sensors on both indoor unit and wired remote controller are active.

**NOTE:** Remote controller sensor must be turned on by using the remote controller.

**8) Remote controller custom code**

(Only for wireless remote controller)

The indoor unit custom code can be changed. Select the appropriate custom code.

Function number	Setting value	Setting description	Factory setting
44	00	A	◆
	01	B	
	02	C	
	03	D	

**9) External input control**

"Operation/Stop" mode or "Forced stop" mode can be selected.

Function number	Setting value	Setting description	Factory setting
46	00	Operation/Stop mode 1	◆
	01	(Setting prohibited)	
	02	Forced stop mode	
	03	Operation/Stop mode 2	

**10) Room temperature sensor switching (Aux.)**

To use the temperature sensor on the wired remote controller only, change the setting to "Wired remote controller" (01).

This function will only work if the function setting 42 is set at "Both" (01).

When the setting value is set to "Both" (00), more suitable control of the room temperature is possible by setting function setting 30 and 31 too.

Function number	Setting value	Setting description	Factory setting
48	00	Both	◆
	01	Wired remote controller	

**11) Indoor unit fan control for energy saving for cooling**

Enables or disables the power-saving function by controlling the indoor unit fan rotation when the outdoor unit is stopped during cooling operation.

Function number	Setting value	Setting description	Factory setting
49	00	Disable	
	01	Enable	
	02	Remote controller	◆

00: When the outdoor unit is stopped, the indoor unit fan operates continuously following the setting on the remote controller.

01: When the outdoor unit is stopped, the indoor unit fan operates intermittently at a very low speed.

02: Enable or disable this function by remote controller setting.

**NOTES:**

- As the factory setting, this setting is initially activated.
- Set to "00" or "01" when connecting a remote controller that cannot set the Fan control for energy saving function or connecting a network converter.  
To confirm if the remote controller has this setting, refer to the operating manual of each remote controller.







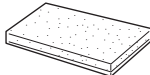
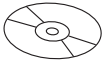

**12) Switching functions for external output terminal**

Functions of the external output terminal can be switched. For details, refer to “External input and output”.

Function number	Setting value	Setting description	Factory setting
60	00	Operation status	◆
	01—08	(Setting prohibited)	
	09	Error status	
	10	Indoor unit fan operation status	
	11	External heater	

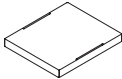
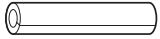
## 10. Accessories

### 10-1. Models: AUXG09KVLA, AUXG12KVLA, AUXG14KVLA, AUXG18KVLA, and AUXG22KVLA

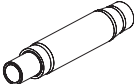
Part name	Exterior	Q'ty	Part name	Exterior	Q'ty
Operating manual		1	Drain hose insulation		1
Operating manual (CD-ROM)		1	Hose band		1
Installation manual		1	Coupler heat insulation (large)		1
Template (Carton top)		1	Coupler heat insulation (small)		1
M10 nut A (with flange)		4	Cable tie		2
M10 nut B (with spring lock washer)		4	Wire crammer		1
Drain hose		1			

# 11. Optional parts

## 11-1. Controllers

Exterior	Part name	Model name	Summary
	Wired remote controller	UTY-RNRGZ*	Easy finger touch operation with LCD panel. Backlit LCD enables easy operation in a dark room. Wire type: Non-polar 2-wire
	Wired remote controller	UTY-RLRG	High visibility and easy operation. Room temperature can be accurately controlled using the built-in thermo sensor. Wire type: Non-polar 2-wire
	Wired remote controller	UTY-RVNGM	Large and full-dot liquid crystal screen, wide and large keys easy to press, user-intuitive arrow key. Wire type: Polar 3-wire
	Wired remote controller	UTY-RNNGM	Room temperature can be controlled by detecting the temperature accurately with built-in thermo sensor. Wire type: Polar 3-wire
	Simple remote controller	UTY-RSRG	Compact remote controller concentrates on the basic functions such as Start/Stop, fan control, temperature setting, and operation mode. Wire type: Non-polar 2-wire
	Simple remote controller	UTY-RHRG	Compact remote controller concentrates on the basic functions such as Start/Stop, fan control, and temperature setting. Wire type: Non-polar 2-wire
	Simple remote controller	UTY-RSNGM	Compact remote controller concentrates on the basic functions such as Start/Stop, fan control, temperature setting, and operation mode. Wire type: Polar 3-wire





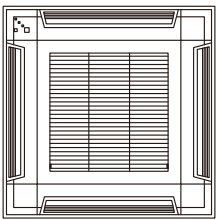

Exterior	Part name	Model name	Summary
	Wireless remote controller	UTY-LNTG	Unit control is performed by wireless remote controller.

**NOTE:** Available functions may differ by the remote controller. For details, refer to the operation manual.

## 11-2. Cassette grille

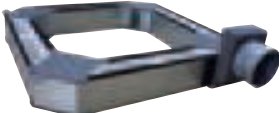
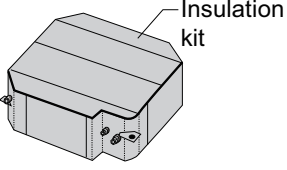
Exterior	Part name	Model name	Summary
	Cassette grille	UTG-UFGF-W	This cassette grille can be installed appropriately on the grid type ceiling common in the office.

## 11-3. Others

Exterior	Part name	Model name	Summary
	External connect kit	UTY-XWZXZG	Use to connect with various peripheral devices and air conditioner PCB. For control output port.
	Air outlet shutter plate	UTR-YDZB	Installed at the air outlet when 3-directions mode is performed.
	Fresh-air intake kit	UTZ-VXAA	By attaching Fresh-air intake kit to the indoor unit, it can be taken in fresh air of up to 10% of "high" air volume of the indoor unit.
	Insulation for high humidity	UTZ-KXGC	Install when the under-roof condition is expected to be the humidity of over 80% and the temperature of over 30 °C.
	Wireless LAN adapter	UTY-TFSXZ1	Remotely manage an air conditioning system using mobile devices such as smartphones and tablets. For connection indoor unit with UART interface.
	Modbus converter	UTY-VMSX	For connection between indoor unit with UART interface and a Modbus open network.
	KNX converter	UTY-VKSX	For connection between indoor unit with UART interface and a KNX open network.
	External switch controller	UTY-TERX	Air conditioner switching can be controlled by connecting other external sensor switches.

**NOTE:** Combined use of following optional parts and Wireless LAN adapter (UTY-TFSXZ1) is not allowed.

- Modbus converter
- KNX converter

# **Part 2. OUTDOOR UNIT**

---

**SINGLE TYPE:**

**AOHG09KBTB**

**AOHG12KBTB**

**AOHG14KBTB**

**AOHG18KBTB**

**AOHG22KBTB**

# 1. Specifications

Type				Inverter heat pump			
Model name				AOHG09KBTB	AOHG12KBTB	AOHG14KBTB	
Power supply				230 V ~ 50 Hz			
Available voltage range				198—264 V			
Starting current				A	4.0	4.8	5.8
Fan	Airflow rate	Cooling	m <sup>3</sup> /h	1,480	1,580	1,670	
		Heating		1,410	1,520	1,580	
	Type × Q'ty	Propeller fan × 1					
Motor output				W			
Sound pressure level *1		Cooling	dB (A)	46	47	49	
		Heating		46	47	49	
Sound power level		Cooling	dB (A)	59	61	62	
		Heating		59	61	62	
Heat exchanger type	Dimensions (H × W × D)		mm	504 × 881 × 18.19			
	Fin pitch			504 × 851 × 18.19			
	Rows × Stages		1.3				
	Pipe type		2 × 24				
	Fin type		Type (Material)	Copper			
			Surface treatment	Aluminum PC fin			
Compressor	Type × Q'ty	W		DC rotary × 1	DC Twin rotary × 1		
	Motor output			900	810	900	
Refrigerant	Type (Global warming potential)		R32 (675)				
	Charge	g		850			
Refrigerant oil	Type		RB68A	FW68S			
	Amount	cm <sup>3</sup>		340	350		
Enclosure	Material			Steel sheet			
	Color			Beige Approximate color of Munsell 10YR 7.5/1.0			
Dimensions (H × W × D)	Net		mm	542 × 799 × 290			
	Gross			602 × 940 × 375			
Weight	Net		kg	32	33		
	Gross			35	37		
Connection pipe	Size	Liquid	mm (in)	Ø 6.35 (Ø 1/4)			
		Gas		Ø 9.52 (Ø 3/8)			
	Method			Flare			
	Pre-charge length			15			
	Max. length		m	20	25		
Max. height difference		15		20			
Operation range		Cooling	°C	-15 to 46			
		Heating		-15 to 24			
Drain hose	Material			PP			
	Size			mm Ø 13.0 (I. D.), Ø 16.0 to Ø 16.8 (O. D.)			
<b>NOTES:</b>							
<ul style="list-style-type: none"> <li>• Specifications are based on the following conditions: <ul style="list-style-type: none"> <li>– Cooling: Indoor temperature of 27 °CDB/19 °CWB, and outdoor temperature of 35 °CDB/24 °CWB.</li> <li>– Heating: Indoor temperature of 20 °CDB/15 °CWB, and outdoor temperature of 7 °CDB/6 °CWB.</li> <li>– Pipe length: 5 m, Height difference: 0 m.</li> </ul> </li> <li>• Protective function might work when using it outside the operation range.</li> <li>• *1: Sound pressure level <ul style="list-style-type: none"> <li>– Measured values in manufacturer's anechoic chamber.</li> <li>– Because of the surrounding sound environment, the sound levels measured in actual installation conditions might be higher than the specified values here.</li> </ul> </li> <li>• This data is based on EN 14511 standard.</li> </ul>							

Type			Inverter heat pump		
Model name			AOHG18KBTB	AOHG22KBTB	
Power supply			230 V ~ 50 Hz		
Available voltage range			198—264 V		
Starting current			A	7.1	8.2
Fan	Airflow rate	Cooling	m <sup>3</sup> /h	2,160	2,240
		Heating		1,830	1,960
	Type × Q'ty	Propeller fan × 1			
Motor output			W	49	
Sound pressure level *1		Cooling	dB (A)	50	51
		Heating		50	51
Sound power level		Cooling	dB (A)	62	63
		Heating		62	63
Heat exchanger type	Dimensions (H × W × D)		mm	588 × 881 × 18.19	588 × 881 × 18.19
				588 × 851 × 18.19	588 × 851 × 18.19
	Fin pitch	1.3			
	Rows × Stages	2 × 28		2 × 28	
	Pipe type	Copper			
Fin type	Type (Material)	Corrugate (Aluminum)			
	Surface treatment	*PC fin*		Corrosion resistance	
Compressor	Type × Q'ty	DC Twin rotary × 1			
	Motor output	W	900	1,060	
Refrigerant	Type (Global warming potential)	R32 (675)			
	Charge	g	1,020	1,250	
Refrigerant oil	Type	FW68S			
	Amount	cm <sup>3</sup>	350	RmM68AF 400	
Enclosure	Material	Steel sheet			
	Color	Beige Approximate color of Munsell 10YR 7.5/1.0			
Dimensions (H × W × D)	Net	mm	632 × 799 × 290		
	Gross		692 × 940 × 375		
Weight	Net	kg	36	38	
	Gross		40	42	
Connection pipe	Size	Liquid	mm (in)	Ø 6.35 (Ø 1/4)	
		Gas		Ø 12.70 (Ø 1/2)	
	Method	Flare			
	Pre-charge length	m	20		
	Max. length		30		
Max. height difference	20		25		
Operation range	Cooling	°C	-15 to 46		
	Heating		-15 to 24		
Drain hose	Material	PP			
	Size	mm	Ø 13.0 (I. D.), Ø 16.0 to Ø 16.8 (O. D.)		

**NOTES:**

- Specifications are based on the following conditions:
  - Cooling: Indoor temperature of 27 °CDB/19 °CWB, and outdoor temperature of 35 °CDB/24 °CWB.
  - Heating: Indoor temperature of 20 °CDB/15 °CWB, and outdoor temperature of 7 °CDB/6 °CWB.
  - Pipe length: 5 m, Height difference: 0 m.
- Protective function might work when using it outside the operation range.
- \*1: Sound pressure level
  - Measured values in manufacturer's anechoic chamber.
  - Because of the surrounding sound environment, the sound levels measured in actual installation conditions might be higher than the specified values here.
- This data is based on EN 14511 standard.

## 2. Dimensions

### 2-1. Models: AOHG09KBTB, AOHG12KBTB, and AOHG14KBTB

Unit: mm

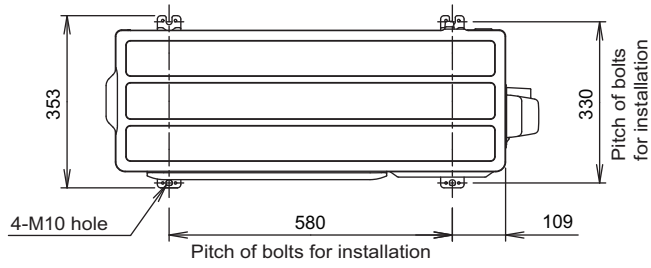

Top view

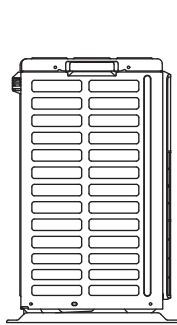

Side view

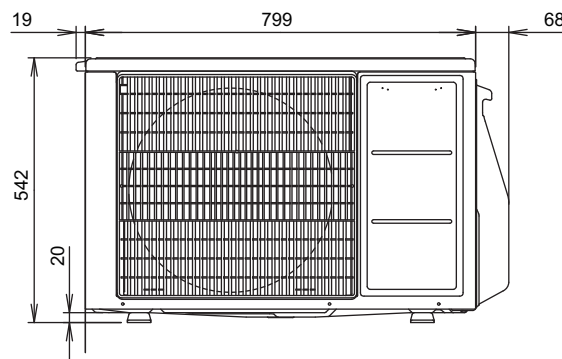

Front view

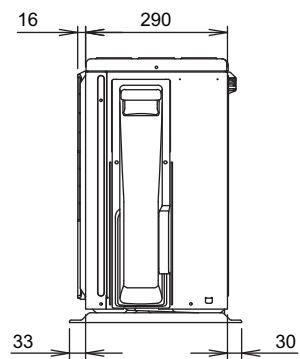

Side view

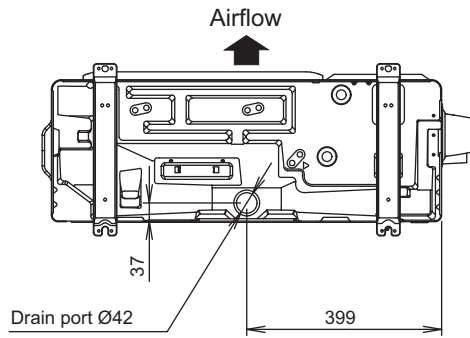

Bottom view

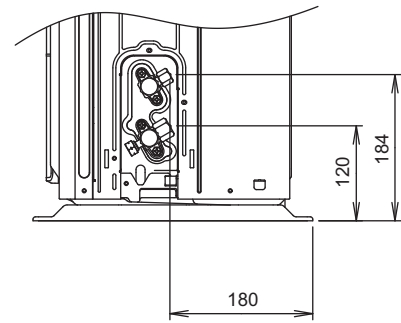

Side view (Valve part)

OUTDOOR UNIT  
AOHG09-22KBTB

OUTDOOR UNIT  
AOHG09-22KBTB

## 2-2. Models: AOHG18KBTB and AOHG22KBTB

Unit: mm

OUTDOOR UNIT  
AOHG09-22KBTB

OUTDOOR UNIT  
AOHG09-22KBTB

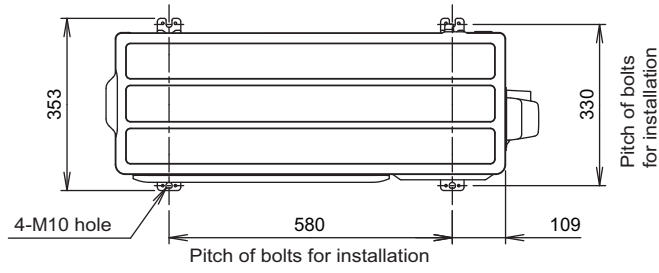

Top view

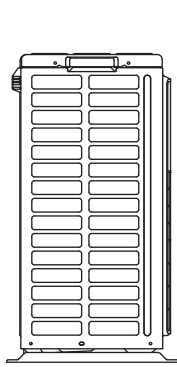

Side view

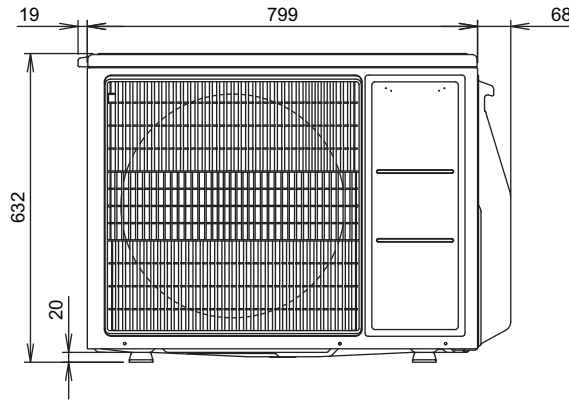

Front view

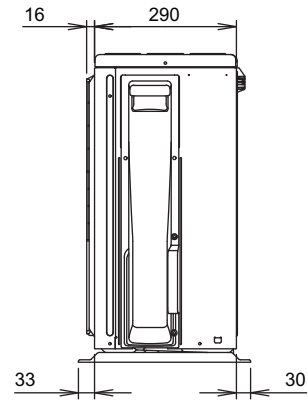

Side view

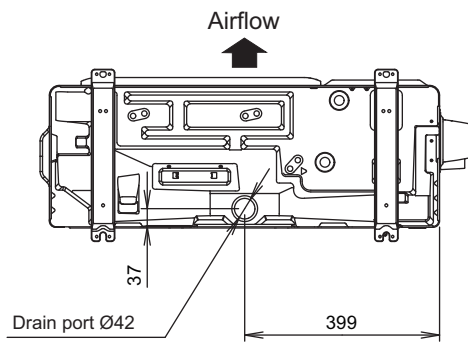

Bottom view

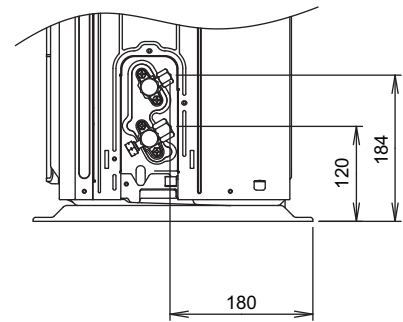

Side view (Valve part)

## 3. Installation space

### 3-1. Models: AOHG09KBTB, AOHG12KBTB, AOHG14KBTB, AOHG18KBTB, and AOHG22KBTB

#### ■ Space requirement

Provide sufficient installation space for product safety.

#### ⚠ CAUTION

Keep the space shown in the installation examples.

If the installation is not performed accordingly, it could cause a short circuit and result in a lack of operating performance.

#### ● Single outdoor unit installation

- When the upper space is open:

Unit: mm

Obstacles at rear only

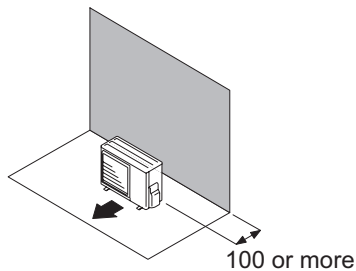

Obstacles at rear and sides

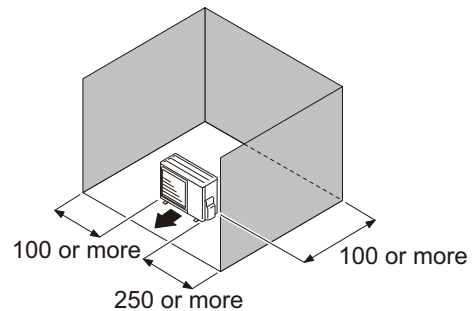

Obstacles at front

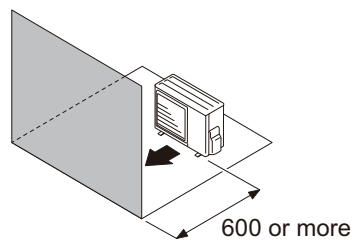

Obstacles at front and rear

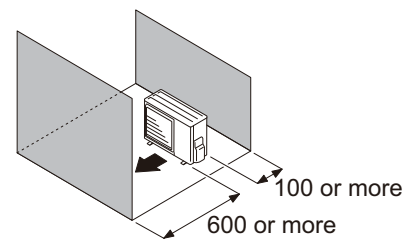

- When an obstruction in the upper space:

Unit: mm

Obstacles at rear and above

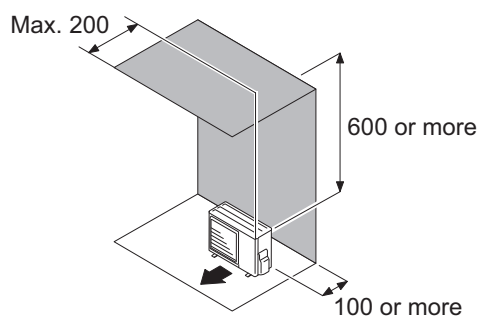

Obstacles at rear, sides, and above

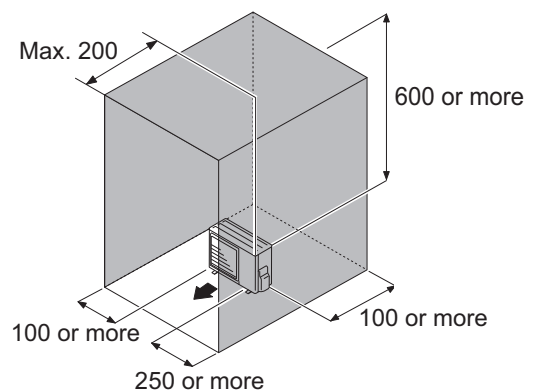

## ● Multiple outdoor unit installation

- Provide at least 250 mm of space between the outdoor units if multiple units are installed.
- When routing the piping from the side of an outdoor unit, provide space for piping.
- No more than 3 units must be installed side by side.  
When 4 units or more are arranged in a line, provide the space as shown in the following example **“When an obstruction in the upper space:”**.
- **When the upper space is open:**

Unit: mm

Obstacles at rear only

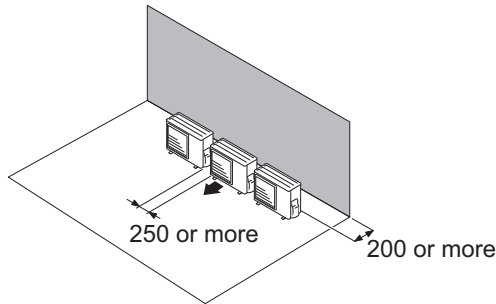

Obstacles at front only

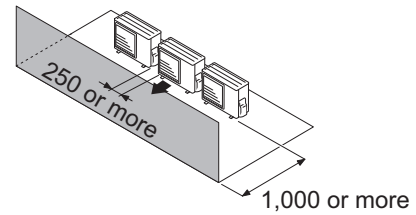

Obstacles at front and rear

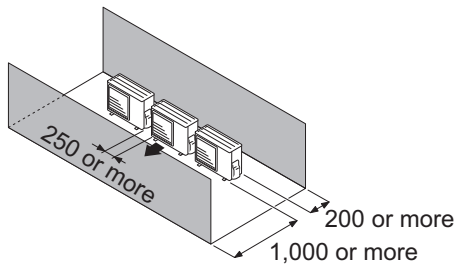

- **When an obstruction in the upper space:**

Unit: mm

Obstacles at rear and above.

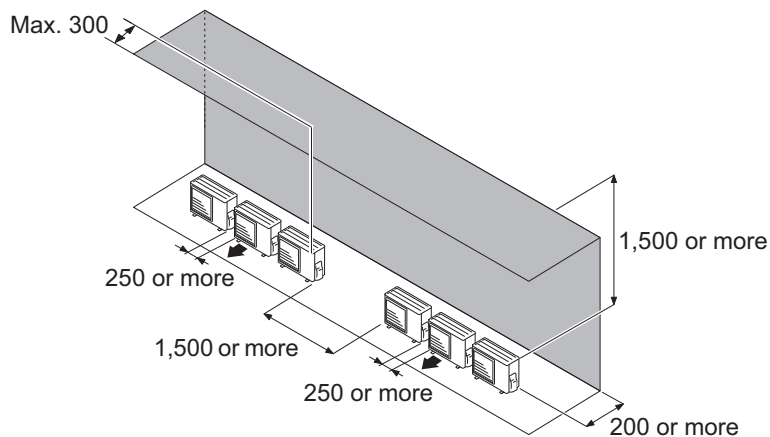

## ● Outdoor units installation in multi-row

Unit: mm

Single parallel unit arrangement

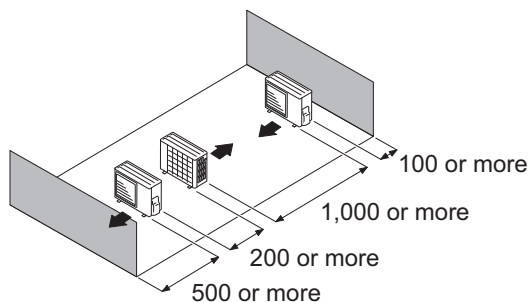

Multiple parallel unit arrangement

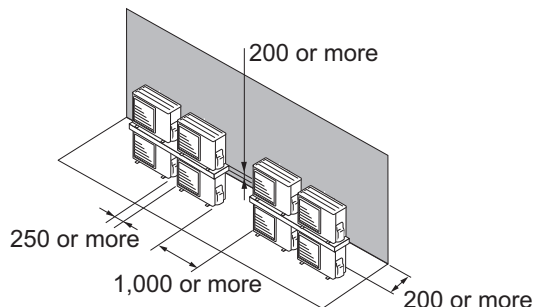
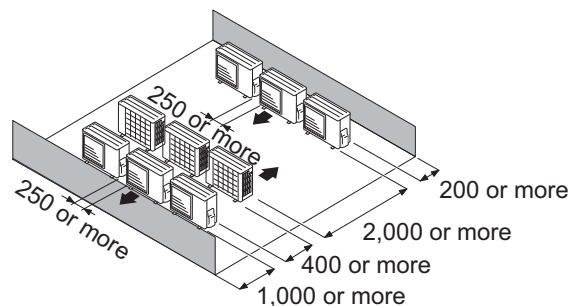

### NOTES:

- If the space is larger than stated above, the condition will be the same as when there is no obstacle.
- When installing the outdoor unit, be sure to open the front and left side to obtain better operation efficiency.

### ⚠ CAUTION

- Do not install the outdoor unit in two-stage where the drain water could freeze. Otherwise the drainage from the upper unit may form ice and cause a malfunction of the lower unit.
- When the outdoor temperature is 0 °C or less, do not use the accessory drain pipe and drain cap. If the drain pipe and drain cap are used, the drain water in the pipe may freeze in extremely cold climate. (For reverse cycle model only.)
- In area with heavy snowfall, if the inlet and outlet of the outdoor unit is blocked with snow, it might become difficult to get warm, and it is likely to cause product malfunction. Construct a canopy and a pedestal, or place the unit on a high stand that is locally installed.

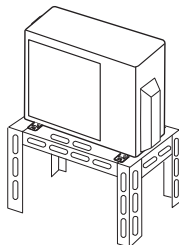

## 4. Refrigerant circuit

### 4-1. Models: AOHG09KBTB, AOHG12KBTB, and AOHG14KBTB

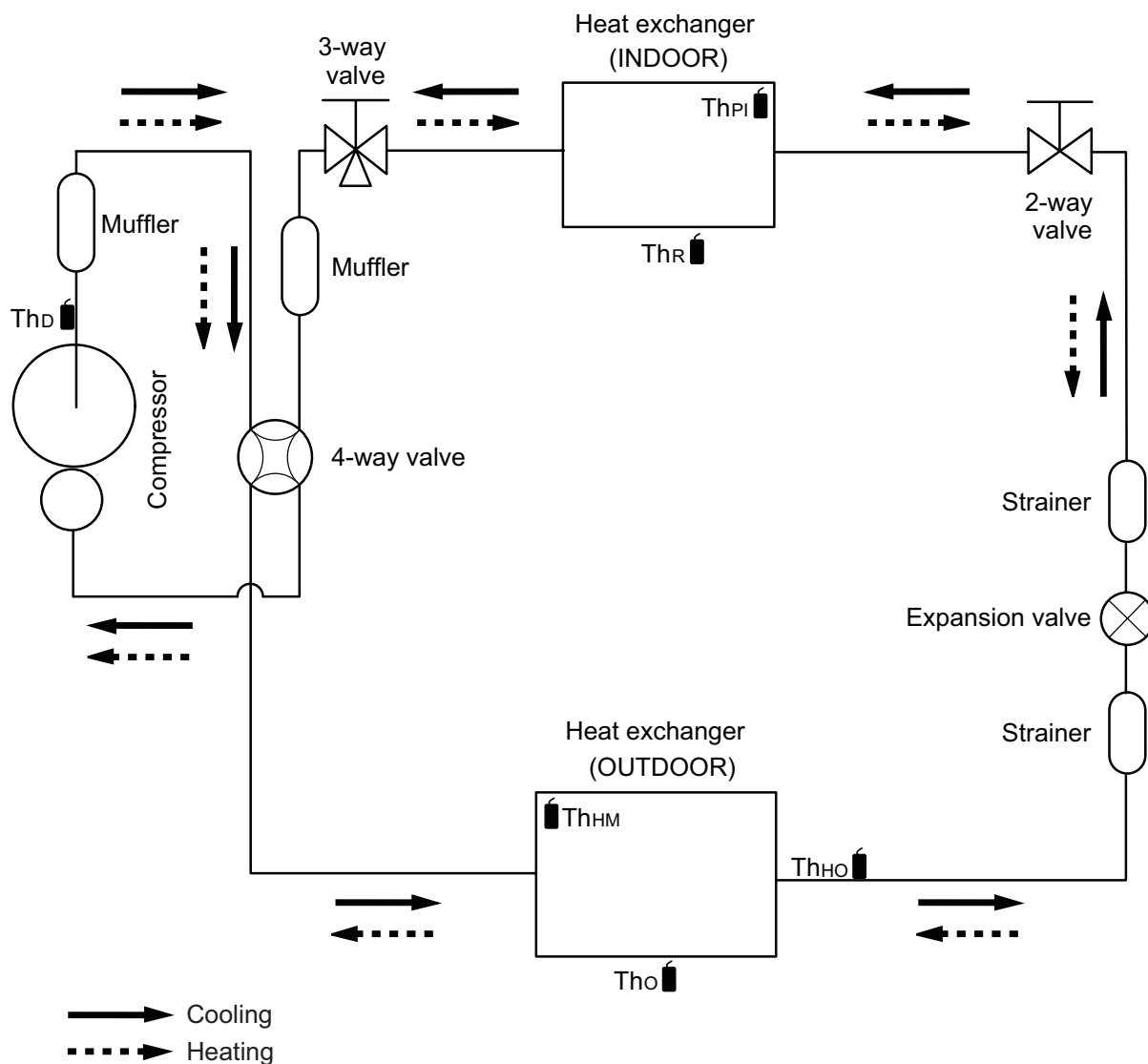

$Th_D$  : Thermistor (Discharge temperature)

$Th_o$  : Thermistor (Outdoor temperature)

$Th_o$  : Thermistor (Heat exchanger out temperature)

$Th_{HM}$  : Thermistor (Heat exchanger middle temperature)

$Th_R$  : Thermistor (Room temperature)

$Th_{PI}$  : Thermistor (Pipe temperature)

# 4-2. Model: AOHG18KBTB

OUTDOOR UNIT  
AOHG09-22KBTB

OUTDOOR UNIT  
AOHG09-22KBTB

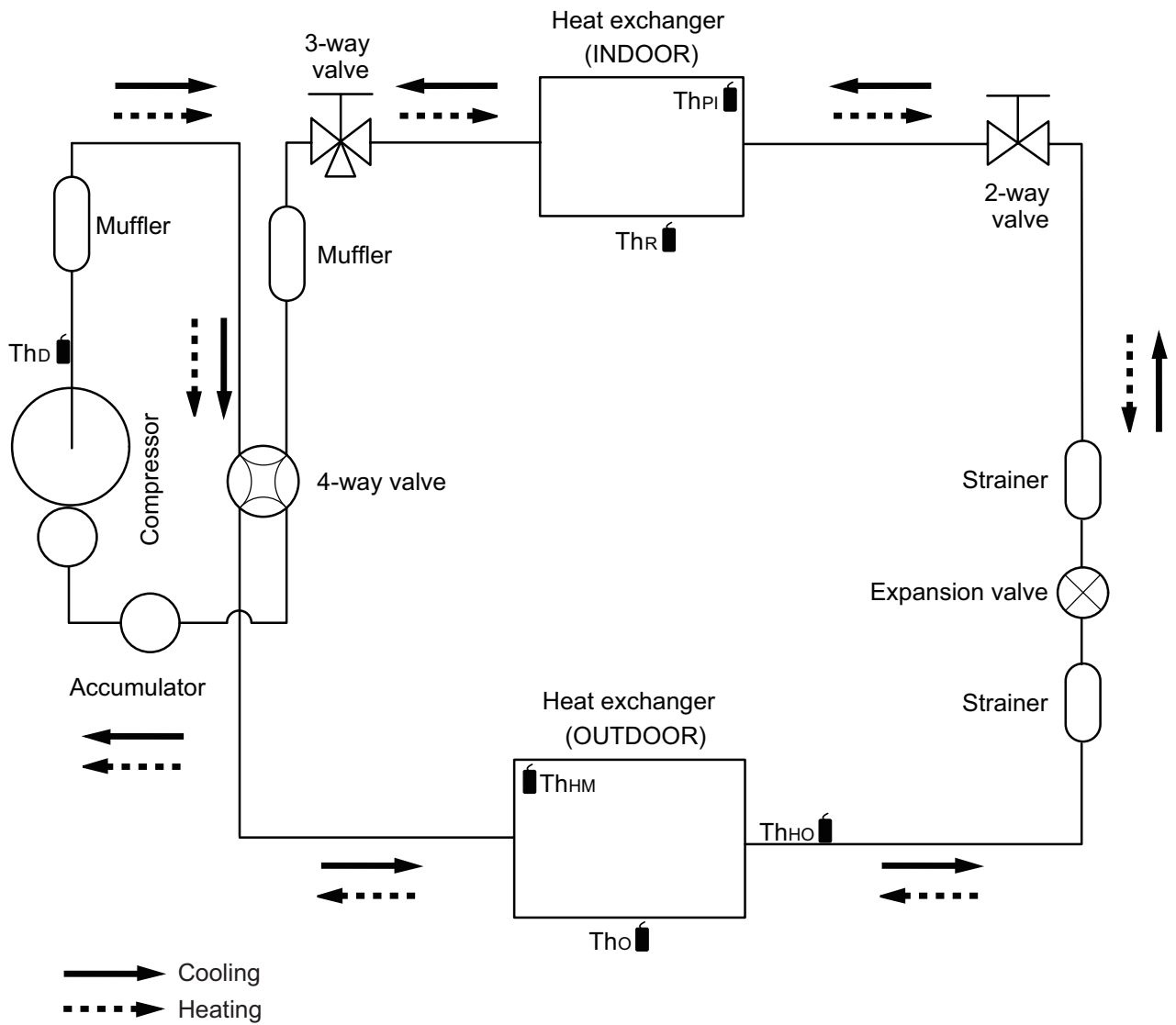

- Th<sub>D</sub> : Thermistor (Discharge temperature)
- Th<sub>O</sub> : Thermistor (Outdoor temperature)
- Th<sub>HO</sub> : Thermistor (Heat exchanger out temperature)
- Th<sub>HM</sub> : Thermistor (Heat exchanger middle temperature)
- Th<sub>R</sub> : Thermistor (Room temperature)
- Th<sub>PI</sub> : Thermistor (Pipe temperature)

### 4-3. Model: AOHG22KBTB

OUTDOOR UNIT  
AOHG09-22KBTB

OUTDOOR UNIT  
AOHG09-22KBTB

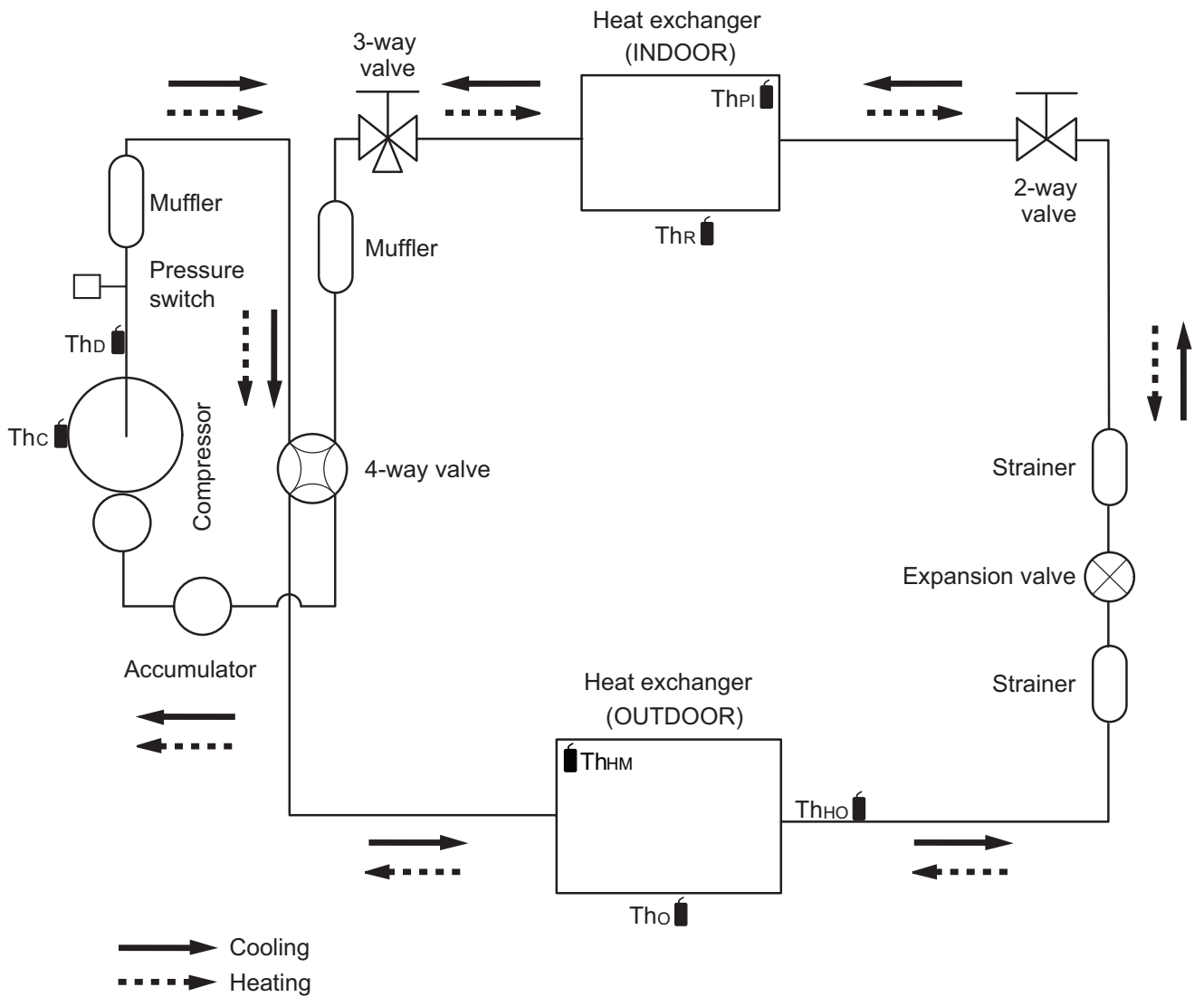

- Thc : Thermistor (Compressor temperature)
- Thd : Thermistor (Discharge temperature)
- Tho : Thermistor (Outdoor temperature)
- Thho : Thermistor (Heat exchanger out temperature)
- Thhm : Thermistor (Heat exchanger middle temperature)
- Thr : Thermistor (Room temperature)
- Thpi : Thermistor (Pipe temperature)

# 5. Wiring diagrams

## 5-1. Model: AOHG09KBTB

OUTDOOR UNIT  
AOHG09-22KBTB

OUTDOOR UNIT  
AOHG09-22KBTB

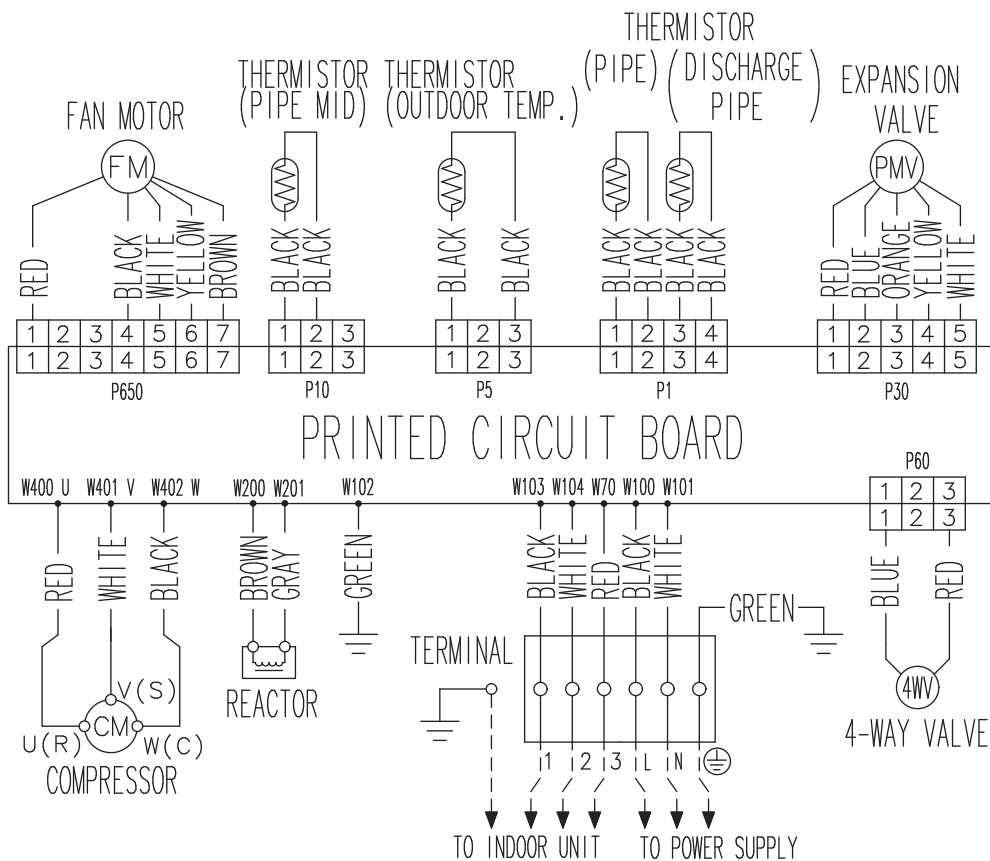

## 5-2. Models: AOHG12KBTB, AOHG14KBTB, and AOHG18KBTB

OUTDOOR UNIT  
AOHG09-22KBTB

OUTDOOR UNIT  
AOHG09-22KBTB

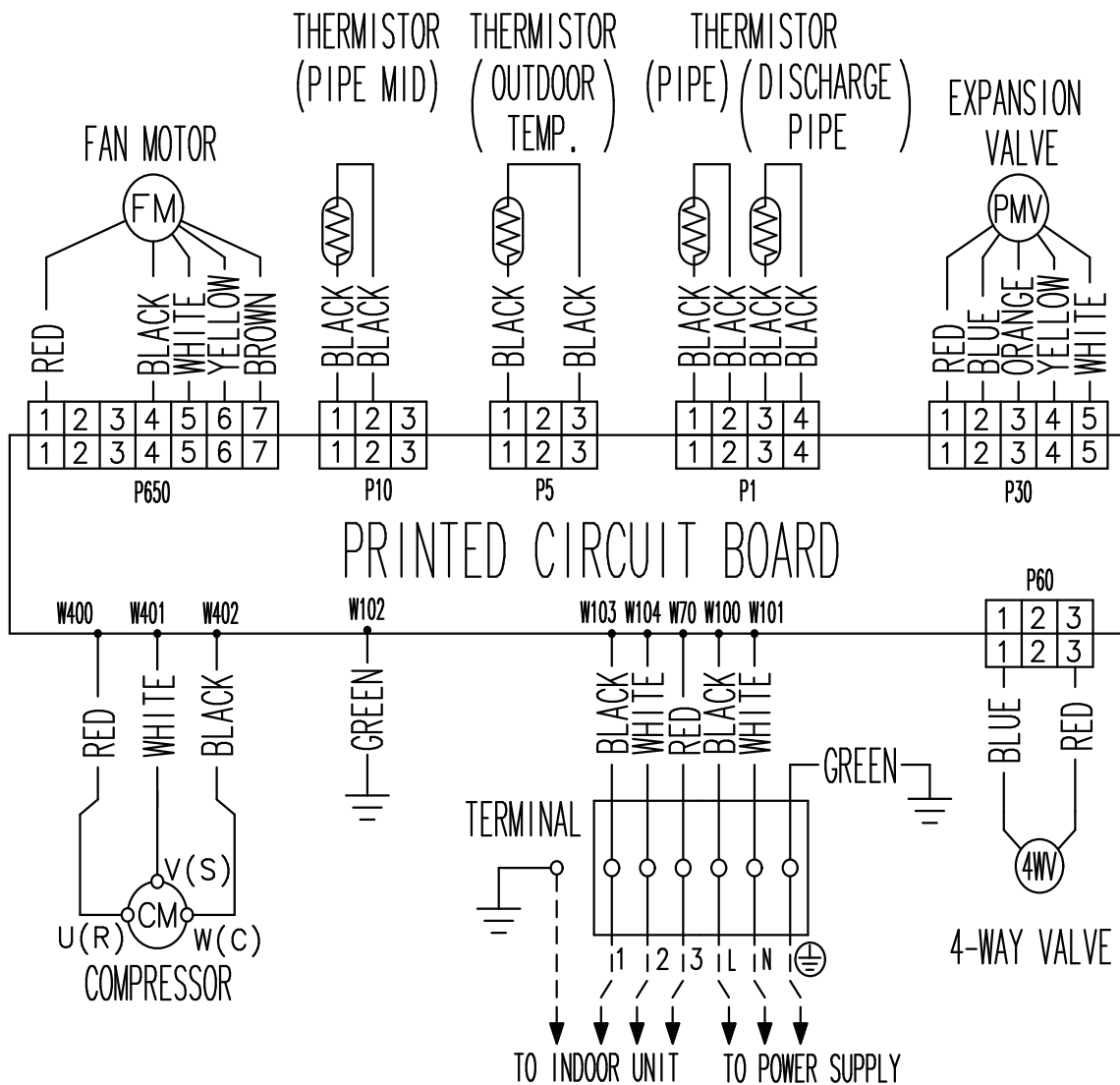

# 5-3. Model: AOHG22KBTB

OUTDOOR UNIT  
AOHG09-22KBTB

OUTDOOR UNIT  
AOHG09-22KBTB

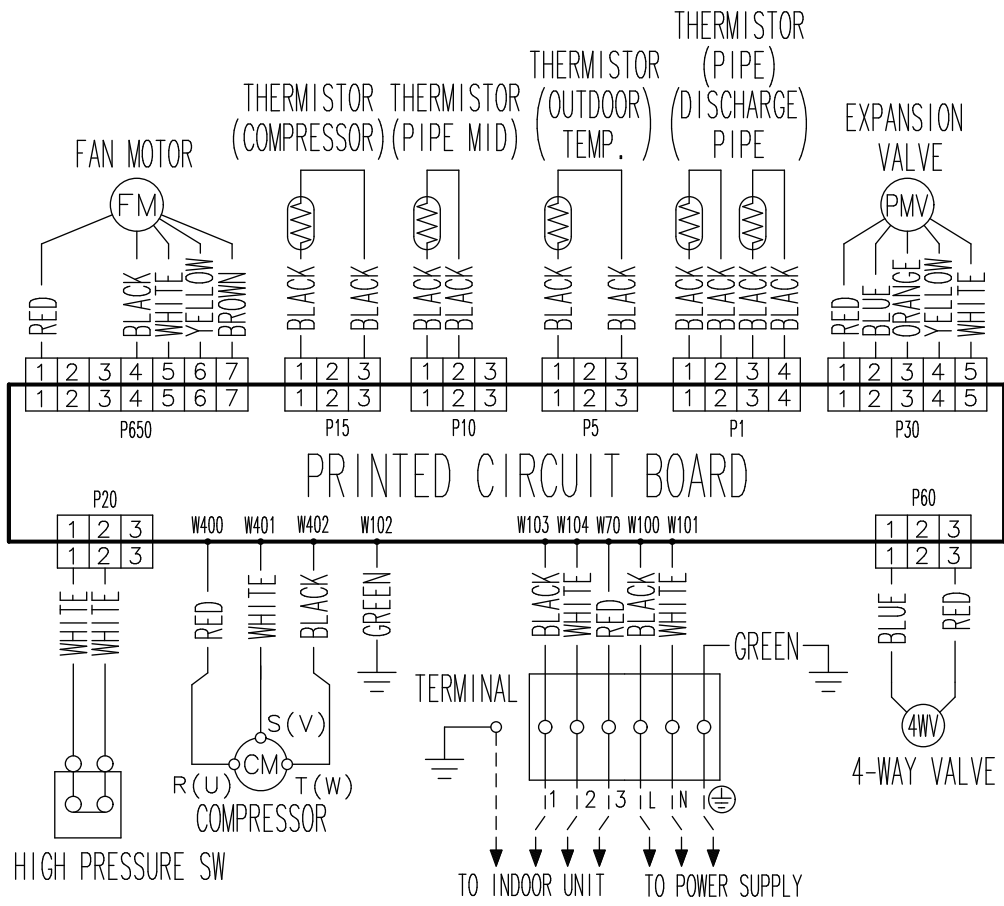

## 6. Capacity compensation rate for pipe length and height difference

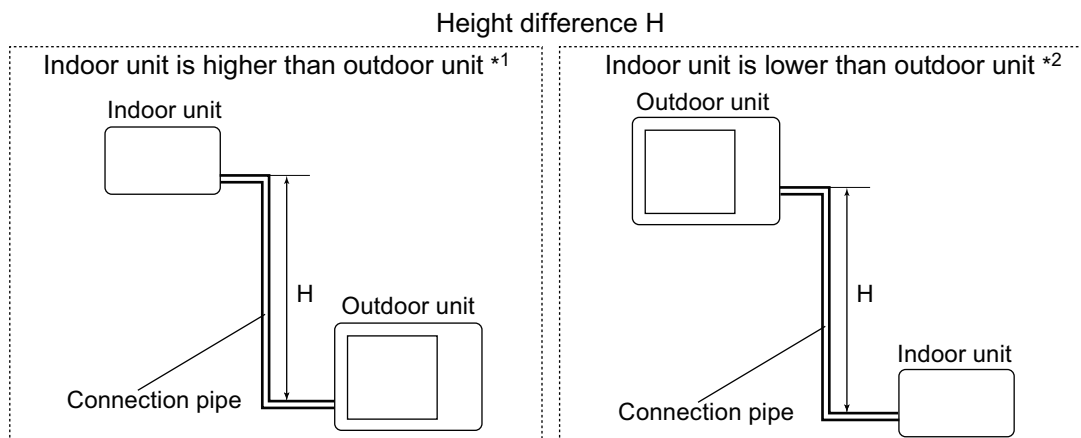

### 6-1. Model: AOHG09KBTB

**NOTE:** Values mentioned in the table are calculated based on the maximum capacity.

COOLING			Pipe length (m)				
			5	7.5	10	15	20
Height difference H (m)	Indoor unit is higher than outdoor unit *1	15	—	—	—	0.903	0.894
		10	—	—	0.964	0.918	0.909
		7.5	—	0.988	0.968	0.922	0.912
		5	0.992	0.992	0.972	0.925	0.916
	Indoor unit is lower than outdoor unit *2	0	1.000	1.000	0.980	0.933	0.923
		-5	1.000	1.000	0.980	0.933	0.923
		-7.5	—	1.000	0.980	0.933	0.923
		-10	—	—	0.980	0.933	0.923
		-15	—	—	—	0.933	0.923

HEATING			Pipe length (m)				
			5	7.5	10	15	20
Height difference H (m)	Indoor unit is higher than outdoor unit *1	15	—	—	—	0.943	0.916
		10	—	—	1.010	0.943	0.916
		7.5	—	1.000	1.010	0.943	0.916
		5	1.000	1.000	1.010	0.943	0.916
		0	1.000	1.000	1.010	0.943	0.916
	Indoor unit is lower than outdoor unit *2	-5	0.995	0.995	1.005	0.939	0.912
		-7.5	—	0.993	1.002	0.936	0.909
		-10	—	—	0.999	0.934	0.907
		-15	—	—	—	0.925	0.898

## 6-2. Model: AOHG12KBTB

**NOTE:** Values mentioned in the table are calculated based on the maximum capacity.

COOLING			Pipe length (m)					
			5	7.5	10	15	20	25
Height difference H (m)	Indoor unit is higher than outdoor unit *1	20	—	—	—	—	0.879	0.851
		15	—	—	—	0.903	0.894	0.867
		10	—	—	0.964	0.918	0.909	0.881
		7.5	—	0.988	0.968	0.922	0.912	0.885
		5	0.992	0.992	0.972	0.925	0.916	0.888
	Indoor unit is lower than outdoor unit *2	0	1.000	1.000	0.980	0.933	0.923	0.895
		-5	1.000	1.000	0.980	0.933	0.923	0.895
		-7.5	—	1.000	0.980	0.933	0.923	0.895
		-10	—	—	0.980	0.933	0.923	0.895
		-15	—	—	—	0.933	0.923	0.895
	-20	—	—	—	—	0.923	0.895	

HEATING			Pipe length (m)					
			5	7.5	10	15	20	25
Height difference H (m)	Indoor unit is higher than outdoor unit *1	20	—	—	—	—	0.916	0.896
		15	—	—	—	0.943	0.916	0.896
		10	—	—	1.010	0.943	0.916	0.896
		7.5	—	1.000	1.010	0.943	0.916	0.896
		5	1.000	1.000	1.010	0.943	0.916	0.896
	Indoor unit is lower than outdoor unit *2	0	1.000	1.000	1.010	0.943	0.916	0.896
		-5	0.995	0.995	1.005	0.939	0.912	0.892
		-7.5	—	0.993	1.002	0.936	0.909	0.890
		-10	—	—	0.999	0.934	0.907	0.887
		-15	—	—	—	0.925	0.898	0.878
	-20	—	—	—	—	0.890	0.868	

## 6-3. Model: AOHG14KBTB

**NOTE:** Values mentioned in the table are calculated based on the maximum capacity.

COOLING			Pipe length (m)					
			5	7.5	10	15	20	25
Height difference H (m)	Indoor unit is higher than outdoor unit *1	20	—	—	—	—	0.932	0.930
		15	—	—	—	0.953	0.950	0.947
		10	—	—	0.983	0.968	0.966	0.962
		7.5	—	0.988	0.987	0.972	0.970	0.966
		5	0.992	0.992	0.991	0.976	0.974	0.970
	Indoor unit is lower than outdoor unit *2	0	1.000	1.000	0.999	0.984	0.982	0.978
		-5	1.000	1.000	0.999	0.984	0.982	0.978
		-7.5	—	1.000	0.999	0.984	0.982	0.978
		-10	—	—	0.999	0.984	0.982	0.978
		-15	—	—	—	0.984	0.982	0.978
	-20	—	—	—	—	0.982	0.978	

HEATING			Pipe length (m)					
			5	7.5	10	15	20	25
Height difference H (m)	Indoor unit is higher than outdoor unit *1	20	—	—	—	—	0.891	0.862
		15	—	—	—	0.918	0.891	0.862
		10	—	—	0.981	0.918	0.891	0.862
		7.5	—	1.000	0.981	0.918	0.891	0.862
		5	1.000	1.000	0.981	0.918	0.891	0.862
	Indoor unit is lower than outdoor unit *2	0	1.000	1.000	0.981	0.918	0.891	0.862
		-5	0.995	0.995	0.976	0.914	0.886	0.858
		-7.5	—	0.993	0.974	0.912	0.884	0.856
		-10	—	—	0.972	0.909	0.882	0.854
		-15	—	—	—	0.900	0.873	0.845
	-20	—	—	—	—	0.863	0.834	

## 6-4. Model: AOHG18KBTB

**NOTE:** Values mentioned in the table are calculated based on the maximum capacity.

COOLING			Pipe length (m)						
			5	7.5	10	15	20	25	30
Height difference H (m)	Indoor unit is higher than outdoor unit *1	20	—	—	—	—	0.932	0.930	0.924
		15	—	—	—	0.953	0.950	0.947	0.941
		10	—	—	0.983	0.968	0.966	0.962	0.956
		7.5	—	0.988	0.987	0.972	0.970	0.966	0.960
		5	0.992	0.992	0.991	0.976	0.974	0.970	0.964
	Indoor unit is lower than outdoor unit *2	0	1.000	1.000	0.999	0.984	0.982	0.978	0.972
		-5	1.000	1.000	0.999	0.984	0.982	0.978	0.972
		-7.5	—	1.000	0.999	0.984	0.982	0.978	0.972
		-10	—	—	0.999	0.984	0.982	0.978	0.972
		-15	—	—	—	0.984	0.982	0.978	0.972
-20	—	—	—	—	0.982	0.978	0.972		

HEATING			Pipe length (m)						
			5	7.5	10	15	20	25	30
Height difference H (m)	Indoor unit is higher than outdoor unit *1	20	—	—	—	—	0.894	0.867	0.839
		15	—	—	—	0.920	0.894	0.867	0.839
		10	—	—	0.982	0.920	0.894	0.867	0.839
		7.5	—	1.000	0.982	0.920	0.894	0.867	0.839
		5	1.000	1.000	0.982	0.920	0.894	0.867	0.839
	Indoor unit is lower than outdoor unit *2	0	1.000	1.000	0.982	0.920	0.894	0.867	0.839
		-5	0.995	0.995	0.977	0.916	0.889	0.862	0.836
		-7.5	—	0.993	0.975	0.913	0.887	0.860	0.832
		-10	—	—	0.972	0.911	0.885	0.858	0.830
		-15	—	—	—	0.902	0.876	0.849	0.821
-20	—	—	—	—	0.863	0.834	0.809		

## 6-5. Model: AOHG22KBTB

**NOTE:** Values mentioned in the table are calculated based on the maximum capacity.

COOLING			Pipe length (m)						
			5	7.5	10	15	20	25	30
Height difference H (m)	Indoor unit is higher than outdoor unit *1	25	—	—	—	—	0.909	0.909	0.903
		15	—	—	—	0.953	0.950	0.947	0.941
		10	—	—	0.983	0.968	0.966	0.962	0.956
		7.5	—	0.988	0.987	0.972	0.970	0.966	0.960
		5	0.992	0.992	0.991	0.976	0.974	0.970	0.964
	Indoor unit is lower than outdoor unit *2	0	1.000	1.000	0.999	0.984	0.982	0.978	0.972
		-5	1.000	1.000	0.999	0.984	0.982	0.978	0.972
		-7.5	—	1.000	0.999	0.984	0.982	0.978	0.972
		-10	—	—	0.999	0.984	0.982	0.978	0.972
		-15	—	—	—	0.984	0.982	0.978	0.972
-25	—	—	—	—	0.982	0.978	0.972		

HEATING			Pipe length (m)						
			5	7.5	10	15	20	25	30
Height difference H (m)	Indoor unit is higher than outdoor unit *1	25	—	—	—	—	0.894	0.867	0.839
		15	—	—	—	0.920	0.894	0.867	0.839
		10	—	—	0.982	0.920	0.894	0.867	0.839
		7.5	—	1.000	0.982	0.920	0.894	0.867	0.839
		5	1.000	1.000	0.982	0.920	0.894	0.867	0.839
	Indoor unit is lower than outdoor unit *2	0	1.000	1.000	0.982	0.920	0.894	0.867	0.839
		-5	0.995	0.995	0.977	0.916	0.889	0.862	0.836
		-7.5	—	0.993	0.975	0.913	0.887	0.860	0.832
		-10	—	—	0.972	0.911	0.885	0.858	0.830
		-15	—	—	—	0.902	0.876	0.849	0.821
-25	—	—	—	—	0.851	0.821	0.795		

## 7. Additional charge calculation

### 7-1. Model: AOHG09KBTB

Refrigerant type		R32
Refrigerant amount	g	850

#### ■ Refrigerant charge

Total pipe length	m	15 or less	20 (Max.)	20 g/m
Additional charge	g	0	100	

### 7-2. Models: AOHG12KBTB and AOHG14KBTB

Refrigerant type		R32
Refrigerant amount	g	850

#### ■ Refrigerant charge

Total pipe length	m	15 or less	20	25 (Max.)	20 g/m
Additional charge	g	0	100	200	

### 7-3. Model: AOHG18KBTB

Refrigerant type		R32
Refrigerant amount	g	1,020

#### ■ Refrigerant charge

Total pipe length	m	20 or less	25	30 (Max.)	20 g/m
Additional charge	g	0	100	200	

### 7-4. Model: AOHG22KBTB

Refrigerant type		R32
Refrigerant amount	g	1,250

#### ■ Refrigerant charge

Total pipe length	m	20 or less	25	30 (Max.)	20 g/m
Additional charge	g	0	100	200	

## 8. Airflow

### 8-1. Model: AOHG09KBTB

#### ● Cooling

m <sup>3</sup> /h	1,480
l/s	411
CFM	871

#### ● Heating

m <sup>3</sup> /h	1,410
l/s	392
CFM	830

### 8-2. Model: AOHG12KBTB

#### ● Cooling

m <sup>3</sup> /h	1,580
l/s	439
CFM	930

#### ● Heating

m <sup>3</sup> /h	1,520
l/s	422
CFM	895

### 8-3. Model: AOHG14KBTB

#### ● Cooling

m <sup>3</sup> /h	1,670
l/s	464
CFM	983

#### ● Heating

m <sup>3</sup> /h	1,580
l/s	439
CFM	930

**8-4. Model: AOHG18KBTB****● Cooling**

m <sup>3</sup> /h	2,160
l/s	600
CFM	1,271

**● Heating**

m <sup>3</sup> /h	1,830
l/s	508
CFM	1,077

**8-5. Model: AOHG22KBTB****● Cooling**

m <sup>3</sup> /h	2,240
l/s	622
CFM	1,318

**● Heating**

m <sup>3</sup> /h	1,960
l/s	544
CFM	1,154

# 9. Operation noise (sound pressure)

## 9-1. Noise level curve

### Model: AOHG09KBTB

#### ● Cooling

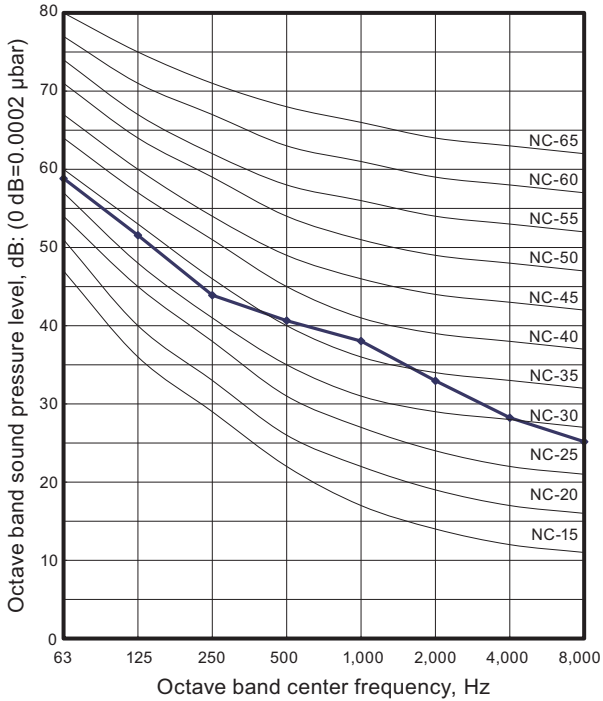

#### ● Heating

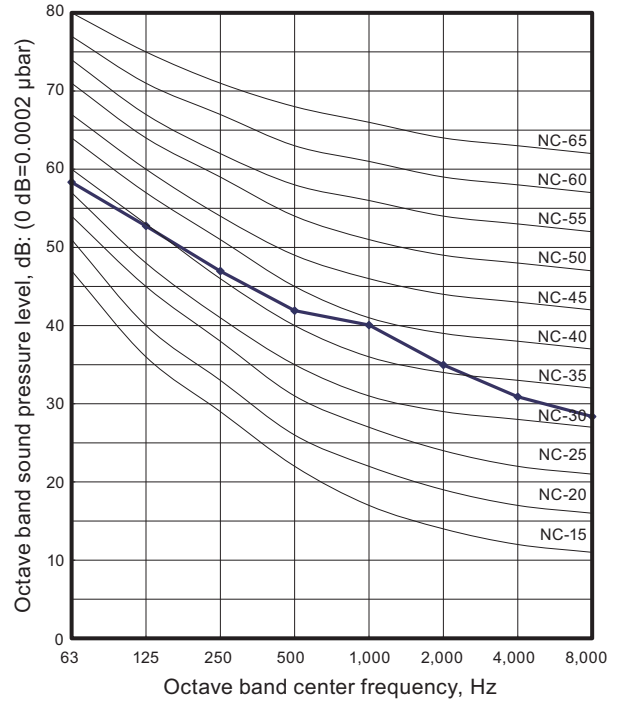

### Model: AOHG12KBTB

#### ● Cooling

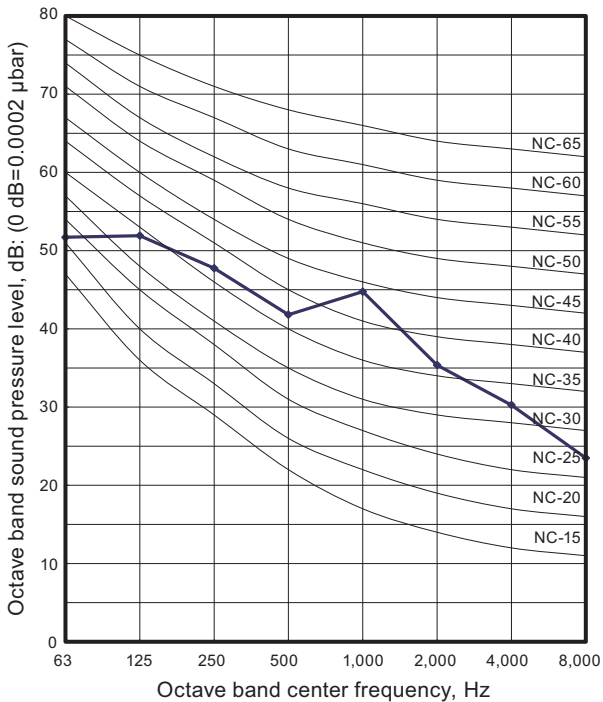

#### ● Heating

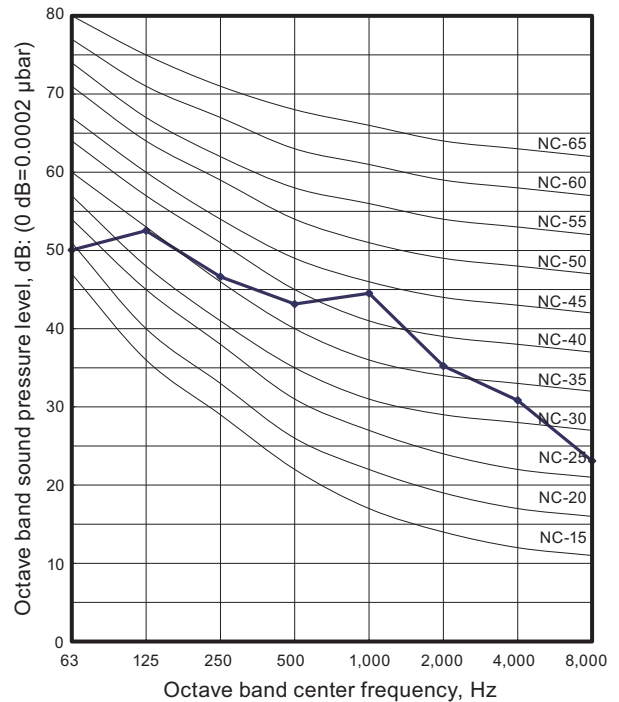

OUTDOOR UNIT  
AOHG09-22KBTB

OUTDOOR UNIT  
AOHG09-22KBTB

## Model: AOHG14KBTB

### Cooling

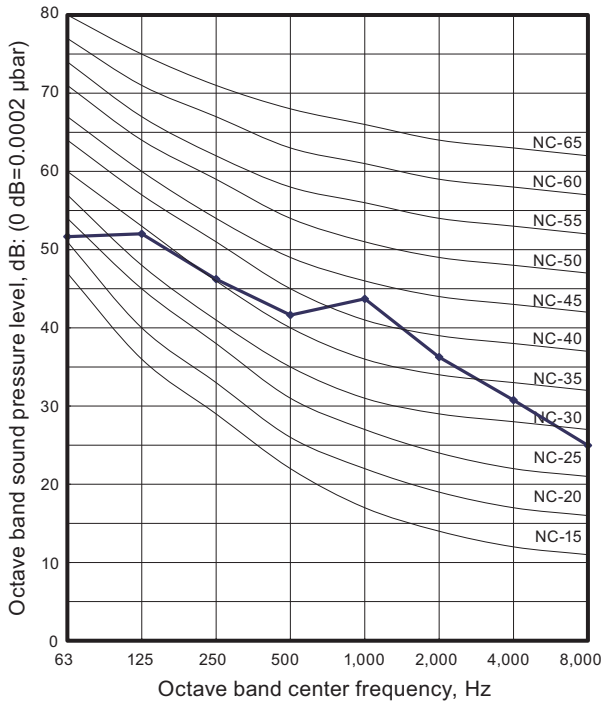

### Heating

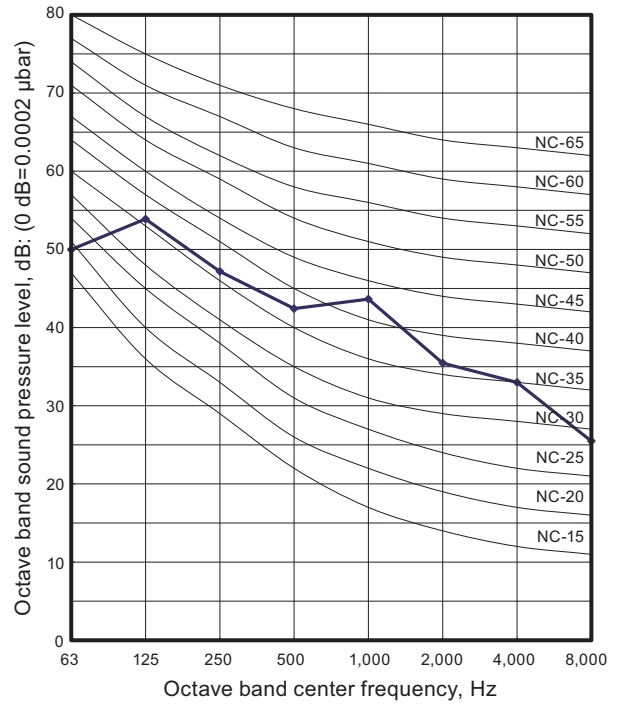

## Model: AOHG18KBTB

### Cooling

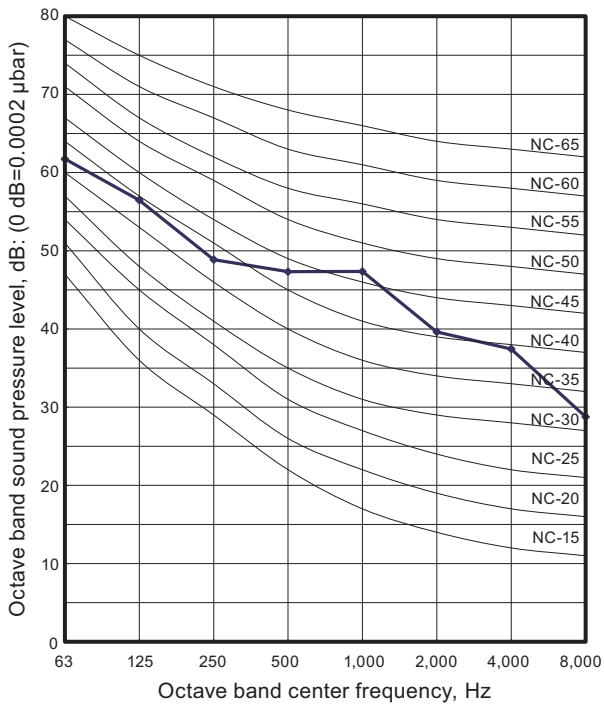

### Heating

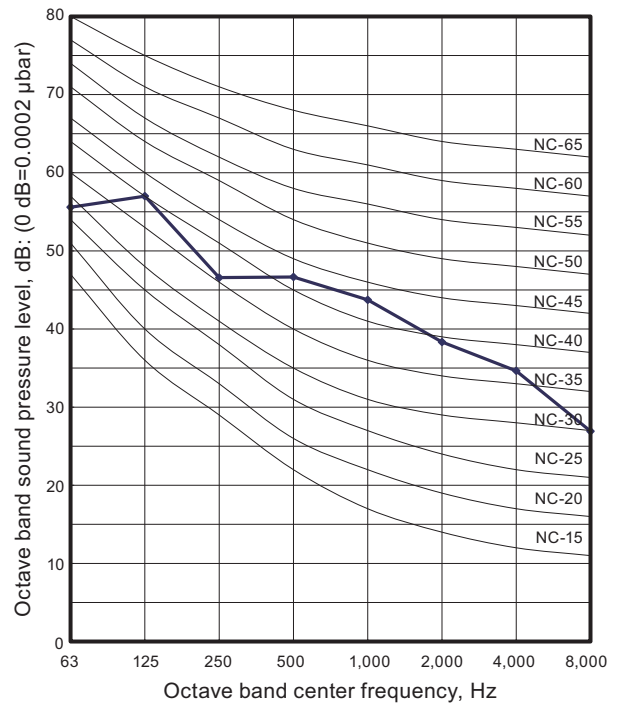

OUTDOOR UNIT  
AOHG09-22KBTB

OUTDOOR UNIT  
AOHG09-22KBTB

■ Model: AOHG22KBTB

● Cooling

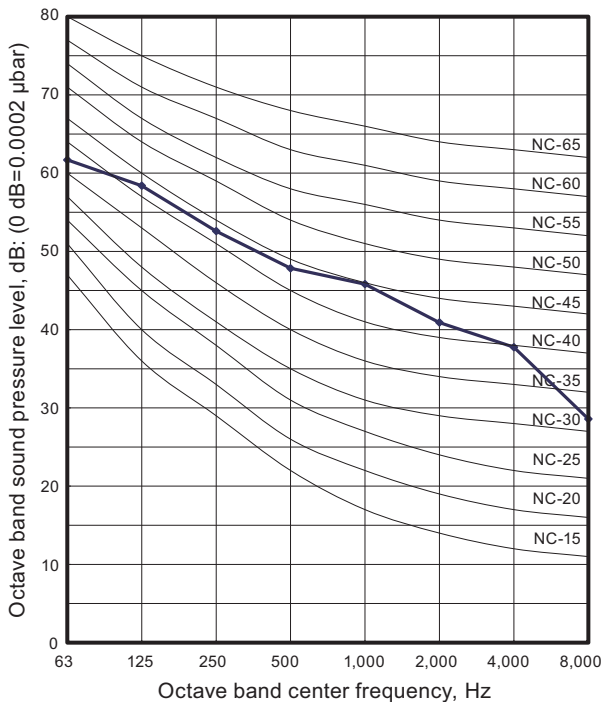

● Heating

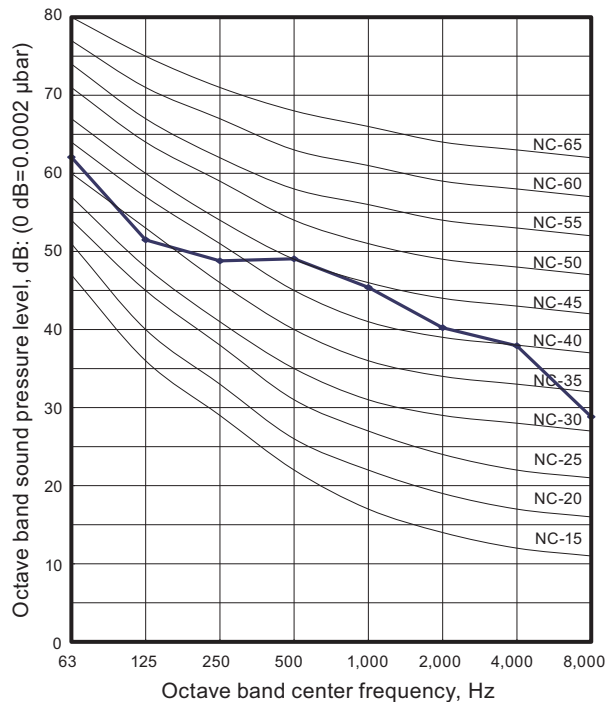

OUTDOOR UNIT  
AOHG09-22KBTB

OUTDOOR UNIT  
AOHG09-22KBTB

9-2. Sound level check point

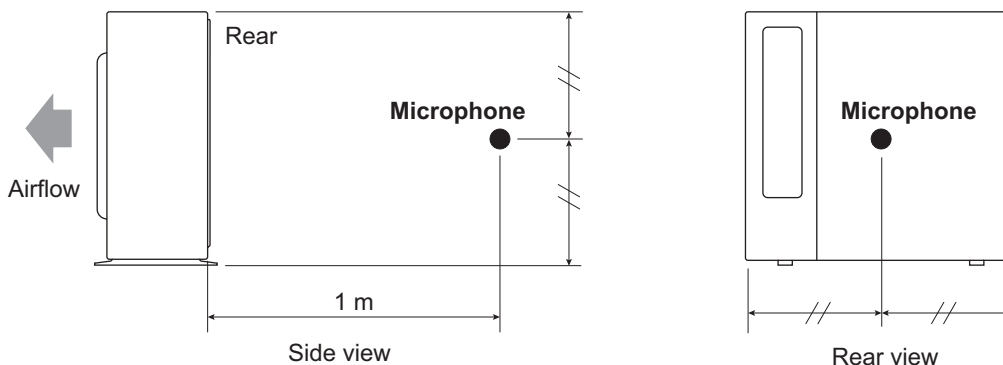

**NOTE:** Detailed shape of the actual outdoor unit might be slightly different from the one illustrated above.

## 10. Electrical characteristics

Model name			AOHG09KBTB	AOHG12KBTB	AOHG14KBTB
Power supply	Voltage	V	230 ~		
	Frequency	Hz	50		
Max operating current *1		A	7.9	9.7	10.2
Starting current		A	4.0	4.8	5.8
Wiring spec. *2	Circuit breaker current		A	10	13
	Power cable		mm <sup>2</sup>	1.5	
	Connection cable *3	Cross-sectional area	mm <sup>2</sup>	1.5	
		Limited wiring length	m	21	26

Model name			AOHG18KBTB	AOHG22KBTB
Power supply	Voltage	V	230 ~	
	Frequency	Hz	50	
Max operating current *1		A	12.1	12.6
Starting current		A	7.1	8.2
Wiring spec. *2	Circuit breaker current		A	16
	Power cable		mm <sup>2</sup>	1.5
	Connection cable *3	Cross-sectional area	mm <sup>2</sup>	1.5
		Limited wiring length	m	31

\*1: Maximum operating current is the total current of the indoor unit and the outdoor unit.

\*2: Selected sample based on Japan Electrotechnical Standards and Codes Committee E0005. As the regulations of wire size and circuit breaker differ in each country or region, select appropriate devices complied to the regional standard.

\*3: Limit voltage drop to less than 2%. If voltage drop is 2% or more, increase cable conductor size.

# 11. Safety devices

Type of protection	Protection form		Model		
			AOHG09KBTB	AOHG12KBTB	AOHG14KBTB
Circuit protection	Current fuse (Main PCB)		250 V, 20 A	250 V, 25 A	
			250 V, 5 A		
			250 V, 3.15 A		
Fan motor protection	Terminal protection program	Activate	125 ±25 °C Fan motor stop	100 ±15 °C Fan motor stop	
		Reset	100 ±25 °C Fan motor restart	95 ±10 °C Fan motor restart	
Compressor protection	Terminal protection program (Discharge temp.)	Activate	110 °C Compressor stop		
		Reset	After 7 minutes Compressor restart		
	Thermal protection program (Outdoor temp.) (Only in COOL or DRY mode)	Activate	-20 °C Compressor stop		
		Reset	-15 °C Compressor restart		

Type of protection	Protection form		Model		
			AOHG18KBTB	AOHG22KBTB	
Circuit protection	Current fuse (Main PCB)		250 V, 25 A		
			250 V, 5 A		
			250 V, 3.15 A		
Fan motor protection	Terminal protection program	Activate	125±10 °C Fan motor stop		
		Reset	120±10 °C Fan motor restart		
Compressor protection	Terminal protection program (Discharge temp.)	Activate	110 °C Compressor stop		
		Reset	After 7 minutes Compressor restart		
	Terminal protection program (Compressor temp.)	Activate	—	108 °C Compressor stop	
		Reset	—	After 3 minutes, and 80 °C or less Compressor restart	
	Thermal protection program (Outdoor temp.) (Only in COOL or DRY mode)	Activate	-20 °C Compressor stop		
		Reset	-15 °C Compressor restart		
High pressure protection	Pressure switch	Activate	—	4.2 <sup>+0</sup> <sub>-0.15</sub> MPa Compressor stop	
		Reset	—	3.2 ±0.15 MPa Compressor restart	

## 12. Accessories

### 12-1. Models: AOHG09KBTB, AOHG12KBTB, AOHG14KBTB, AOHG18KBTB, and AOHG22KBTB

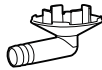
Part name	Exterior	Q'ty	Part name	Exterior	Q'ty
Installation manual		1	Drain pipe		1